

INSTALLATION INSTRUCTIONS



Venting System For
Direct Vent Gas Stoves
and Fireplaces

DIRECT VENT PRO

SIMPSON

Dura-Vent

COMPLETE VENTING SOLUTIONS FOR THE HEARTH INDUSTRY

A MAJOR CAUSE OF VENT RELATED FIRES IS FAILURE TO MAINTAIN REQUIRED CLEARANCES (AIR SPACES) TO COMBUSTIBLE MATERIALS. IT IS OF THE UTMOST IMPORTANCE THAT DIRECTVENT PRO BE INSTALLED ONLY IN ACCORDANCE WITH THESE INSTRUCTIONS.

NOTE:

Read through all of these instructions before beginning your installation. Failure to install as described in this instruction will void the manufacturer's warranty, and may have an effect on your homeowner's insurance and UL listing status. Keep these instructions for future reference.

Dear Customer, Installer, or End User:

I welcome any comments regarding matters pertaining to our Simpson Dura-Vent products. I welcome any ideas, input or complaints and I'll make sure that someone responds directly back to you.

Send your emails to:
president@duravent.com

If you are searching for tech support or product information, please phone us at 800-835-4429.

Or email us at:
techsupport@duravent.com

Sincerely,
Steve Eberhard, President and CEO
Simpson Dura-Vent Co., Inc.

Venting System for Direct Vent Gas Stoves and Fireplaces

DIRECT VENT PRO

CONTENTS

Application | Warning | Safety & Installation Precautions 4

Options | Planning Your Installation 5

Horizontal Installation 6

Snorkels 10

Installing Vinyl Siding Standoff 12

Installing Counter Flashing 13

Vertical Installation 14

Cathedral Ceiling Installation 18

General Maintenance / Labels 20

Supplemental Canadian Instructions 22

Warranty 24

For the most up-to-date installation instructions, see www.dura-vent.com



APPLICATION

These instructions apply to the Simpson Dura-Vent DirectVent Pro 4"x6-5/8" and 5"x8" systems. This venting system, in combination with the gas appliance, has been tested and listed as a decorative gas appliance system or as a direct vent heater system by a major testing agency such as UL, AGA, CGA, OMNI, or Warnock Hersey. Check the manufacturer's rating plate and instruction manual to confirm that the Simpson Dura-Vent Direct Vent is approved for use on the brand name appliance you have selected.

IMPORTANT

Read all instructions carefully before starting the installation. Failure to follow these instructions may create a fire or other safety hazard and will void the warranty. **Check with the appliance manufacturer's installation instructions for specific venting and clearance to combustible requirements, which may vary from one appliance to another.** Be sure to comply with minimum or maximum distances of vertical or horizontal runs as prescribed in the appliance manufacturer's installation instructions.

WARNING

• Always maintain required clearances (air spaces) to nearby combustibles to prevent a fire hazard. Do not fill air spaces with insulation. Be sure to check the appliance manufacturer's installation instructions for minimum clearance requirements between

the outer walls of the vent pipe and nearby combustible surfaces. Be sure to check the vent termination clearance requirements from decks, windows, soffits, gas regulators, air supply inlets, and public walkways, as specified in these installation instructions and local building codes.

- The gas appliance and vent system must be vented directly to the outside of the building, and never be attached to a chimney serving a separate solid fuel or gas-burning appliance. Each direct vent gas appliance must use its own separate vent system. Common vent systems are prohibited.

SAFETY PRECAUTIONS FOR THE INSTALLER

- Wear gloves and safety glasses for protection.
- Exercise extreme caution when using ladders or on roof tops.
- Be aware of electrical wiring locations in walls and ceilings.

INSTALLATION PRECAUTIONS

The Simpson Dura-Vent DirectVent Pro is an engineered product that has been designed and tested for use with approved direct vent gas appliances only. The Simpson Dura-Vent warranty will be voided, and serious fire, health, or other safety hazards may result from any of the following actions:

- Installation of any damaged DirectVent Pro component.
- Unauthorized modification of the DirectVent Pro System

- Installation of any non-DirectVent Pro pipe or component part not approved by Simpson Dura-Vent or the appliance manufacturer.
- Installation other than as instructed by Simpson Dura-Vent or the appliance manufacturer.

Consult your local building codes before beginning the installation.

OPTIONS

The Simpson Dura-Vent DirectVent Pro offers a complete line of component parts for both horizontal and vertical installations. Many items are offered in decorative black as well as galvanized finish. The galvanized pipe and fittings may be used for concealed locations such as attics, or spaces where corrosion is a factor, such as above the roofline. Decorative black painted sections are recommended for use on visible interior runs. Snorkel Terminations are available for applications which may require vertical rise on the building exterior.

PLANNING YOUR INSTALLATION

There are two basic types of DirectVent Pro installations. Check the appliance manufacturer's installation instructions to confirm what types of installations are permitted and check for any venting restrictions such as maximum horizontal run, and minimum or maximum vertical rise. The two types of installations are:

- Horizontal Termination (**Figs. 1 and 2**)

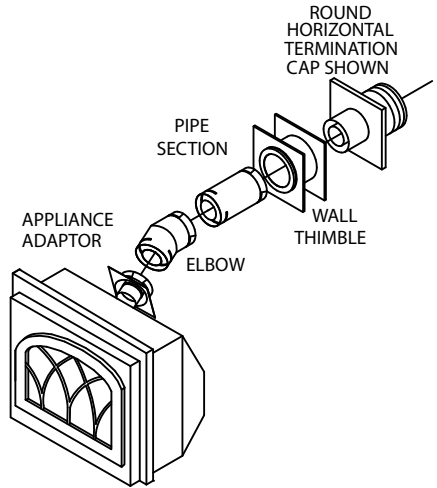

Figure 1

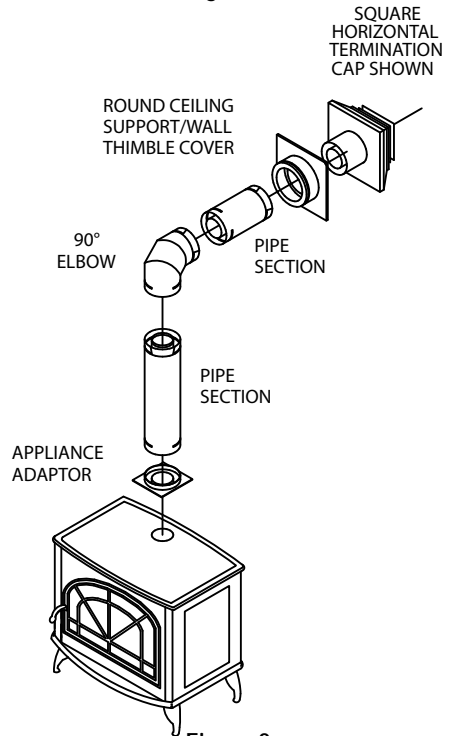

Figure 2

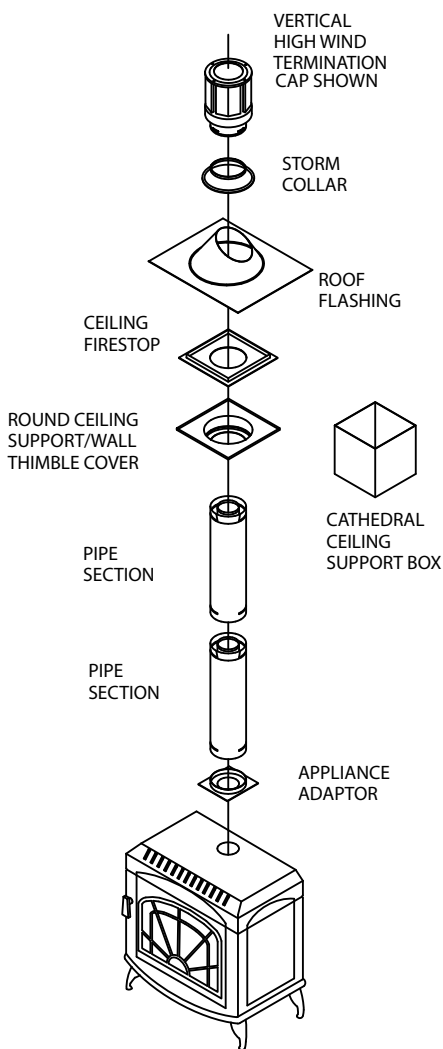

Figure 3

• Vertical Termination (**Fig. 3**)

When planning your installation, it will be necessary to select the proper length of vent pipe for your particular requirements. For horizontal installations, check the appliance manufacturer's installations

instructions to determine the minimum clearance from the rear of the appliance to the wall. It is also important to note the wall thickness. Select the amount of vertical rise desired or required, for "vertical-to-horizontal" installations (verify that it is within the appliance manufacturer's minimum and maximum limits). To determine the length of vent pipe required for vertical installations, measure the distance from the appliance flue outlet to the ceiling, the ceiling thickness, the vertical rise in an attic or second story, and allow for sufficient vent height above the roofline. For two-story applications, Firestops are required at each floor/ceiling level. If an offset is needed in the attic, additional pipe and elbows will be required.

HORIZONTAL INSTALLATION

Step 1. Set the gas appliance in its desired location. Check to determine if wall studs or roof rafters are in the way once the venting system is attached. If this is the case, you may want to adjust the location of the appliance.

Step 2. DirectVent Pro pipe and fittings are designed with special twist-lock connections. To connect the venting system to the appliance flue outlet, a twist-lock Appliance Adaptor is required. With some brands of appliances, the Simpson Dura-Vent Appliance Adaptor will be built into the appliance at the factory. With other brands the adaptor will be supplied by the appliance manufacturer for installation in the field. Assemble the

desired combination of Pipe Sections and Elbows to the Appliance Adaptor (**Fig. 4**).

Notes:

(1) Twist-lock procedure: Line up locking lugs on male and female ends of pipe sections. Insert the male end of pipe into the female end until the locking lugs are covered. Twist the female end clockwise an eighth of a turn to lock sections together (**Fig. 5**). Screws are not required to secure the joint, but are acceptable provided they do not penetrate the inner wall of the vent pipe.

(2) Horizontal runs of vent pipe must be supported to prevent any downward sags. Horizontal pipe sections should be supported at least every 4-feet. Wall Straps can be used for this purpose. Alternatively, plumbers tape or other suitable noncombustible material can be used to support the vent pipe.

(3) DirectVent Pro venting requires no sealant, unless specifically required by appliance manufacturer.

Step 3. With the Appliance Adaptor and Pipe Section attached to the appliance, slide the appliance into its correct location, and mark the wall for a square hole of the appropriate size. Refer to **Table 1, page 8** for the correct size square opening unless otherwise specified by the appliance manufacturer's clearance requirements. The centerline of the pipe should line up with the center of the square hole (**Fig. 6**). Cut and frame the square hole in the exterior wall where the vent will be terminated. A Wall Thimble or

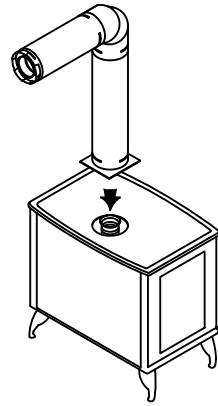

Figure 4

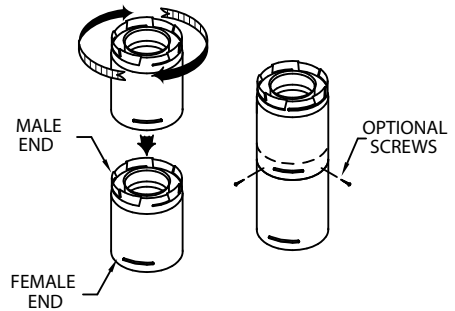

Figure 5

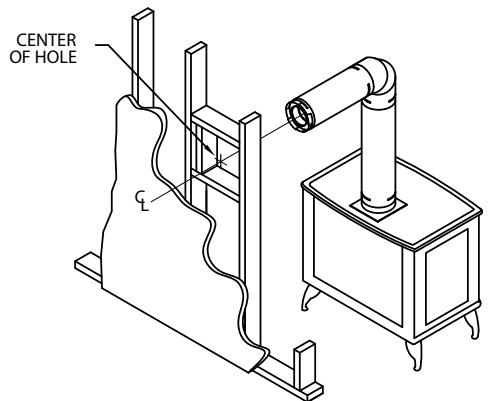

Figure 6

TABLE 1

DIRECTVENT PRO FRAMING OR CUTOUT DIMENSIONS

STOCK NUMBER	COMPONENT DESCRIPTION	SIZE
46DVA-WT	Wall Thimble	10"x 10"
46DVA-WTS	Wall Thimble (Small)	9"x 9"
46DVA-WTU	Wall Thimble Universal	9"x 9"
46DVA-CS	Ceiling Support	10-3/4"x 10-3/4"
46DVA-FS	Fire Stop	9"x 9"
46DVA-WFS	Wall Fire Stop	10"x 10"
46DVA-VSS	Vinyl Siding Standoff	17"x 17"
46DVA-CF	Counter Flashing (Assembled)	13-1/2"x 13-1/2"
46DVA-CFK	Counter Flashing (4pc.Kit)	13-1/2"x 13-1/2"
46DVA-CFKS	Counter Flashing (Kit Small)	10-1/2"x 10-1/2"
46DVA-VSK	Vinyl Siding Standoff (4 Pc.Kit)	13-1/2"x 13-1/2"
46DVA-VSKS	Vinyl Siding Standoff (Kit Small)	10-1/2"x 10-1/2"
46DVA-IS	Insulation Shield	9"x 9"
58DVA-WT	Wall Thimble	10-1/2"x 10-1/2"
58DVA-WTS	Wall Thimble (Small)	9"x 9"
58DVA-WTU	Wall Thimble Universal	9"x 9"
58DVA-CS	Ceiling Support	10-3/4"x 10-3/4"
58DVA-FS	Fire Stop	10-1/2"x 10-1/2"
58DVA-WFS	Wall Fire Stop	10-1/2"x 10-1/2"
58DVA-VSS	Vinyl Siding Standoff	19-1/2"x 19-1/2"
56DVA-VSK	Vinyl Siding Standoff (4 Pc.Kit)	16"x 16"
58DVA-CF	Counter Flashing (Assembled)	16"x 16"
58DVA-CFK	Counter Flashing (4pc.Kit)	16"x 16"
58DVA-IS	Insulation Shield	11"x 11"

Wall Firestop may be required by the appliance manufacturer as additional thermal protection for the wall. If the wall being penetrated is constructed of noncombustible material only, i.e. masonry block, brick, or concrete only, a hole with zero clearance to the vent pipe is permissible if allowed by the appliance manufacturer.

Notes:

(1) The horizontal run of venting must be level, or have a 1/4-inch rise for every 1-foot of run towards the termination. Never allow the vent to run downward. A downward slope can trap heat and become a possible fire hazard.

(2) The location of the Horizontal Vent Termination on an exterior wall must meet all local and national building codes, and must not be easily blocked or obstructed. Termination clearances are as follows:

- (a) Clearance above the ground, veranda, porch, deck, or balcony: 12 inches minimum.
- (b) Clearance to a window (operable or fixed closed) or door: 12 inches minimum.
- (c) Vertical clearance to a ventilated soffit located above the Termination Cap (if soffit extends a horizontal distance of 2 feet out over the centerline of the

termination): 18 inches minimum.

(d) Clearance to an unventilated soffit: 12 inches minimum.

(e) Clearance to an outside corner: as tested by appliance manufacturer.

(f) Clearance to an inside corner: as tested by appliance manufacturer.

(g) Not to be installed above a meter/regulator assembly within 3 feet horizontally from the centerline of the regulator.

(h) Clearance to a service regulator vent outlet: 6 feet minimum.

(i) Clearance to non-mechanical air supply inlet to a building or the combustion air inlet to any other appliance: 12 inches minimum.

(j) Clearance to a mechanical air supply inlet: 6 feet minimum.

(k) Clearance above a paved sidewalk or paved driveway located on public property: refer to local code.

(l) Clearance under a veranda, porch, deck or balcony: 12 inches minimum.

Step 4. Position the Horizontal Termination Cap in the center of the square framed hole, and attach to the exterior wall with the four wood screws provided. Before attaching the vent termination cap to the exterior wall, run a bead of non-hardening silicone sealant around it's outside edges to make a seal between the cap and the wall. The arrow on the vent cap should be pointing up. Ensure that proper clearances to combustible materials are maintained (**Fig. 7**).

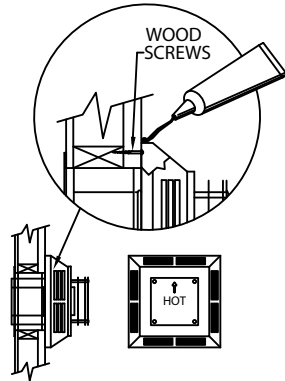

Figure 7

Notes:

(1) The four wood screws provided should be replaced with appropriate fasteners for use on brick, concrete, block, or other types of sidings.

(2) For buildings with vinyl siding or other surfaces, the Vinyl Siding Standoff or Counter Flashing is available.

Step 5. Before connecting your horizontal Pipe Sections to the Horizontal Termination Cap, slide the Wall Thimble Cover over the Pipe Section nearest the interior side of wall

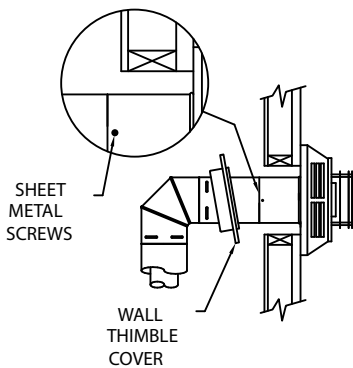

Figure 8

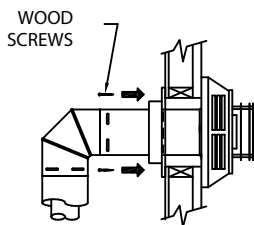

Figure 9

(Fig. 8).

Step 6. Slide the appliance and vent assembly towards the wall, carefully inserting the Pipe Section into the cap assembly. It is important that the Pipe Section extends into the back of the Termination Cap with a minimum overlap of 1-1/4 inches. Use the two sheet metal screws provided to secure the Pipe Section to the back of the Termination Cap. The Wall Thimble Cover will cover the screw heads (Fig. 8).

Step 7. Slide the Wall Thimble Cover up to the wall surface and attach to the wall with screws provided (Fig. 9). Apply optional decorative brass trim to Wall Thimble Cover, if desired.

SNORKELS

For installations requiring a vertical rise on the exterior of the building, 14-inch and 36-inch tall Snorkel Terminations are available (Fig. 10). Follow the same general installation procedures as used for a standard Horizontal Termination. The standard Wall Thimble or Wall Firestop can be used with the Snorkel, but the exterior plate will overhang the edges of the Snorkel. However, a universal Wall Thimble is available for use with the Snorkel that is not visible on the exterior of the building (46 or 58DVA-WTU). To install the Universal Wall Thimble, insert the thimble from the interior of the house and adjust the length of the tube to ensure it touches the backside of the Snorkel when installed (Fig. 10). Secure the tube in place using 2 sheet metal screws. Mount the Wall Thimble in place. Attach the Snorkel to the wall using wood screws or other appropriate fasteners, depending on wall construction. If the Snorkel Termination must be installed below grade level, (e.g. in a basement application), proper drainage must be provided to prevent water from entering the Snorkel Termination (Fig. 11). Do not attempt to enclose the Snorkel within the wall or any other type of enclosure.

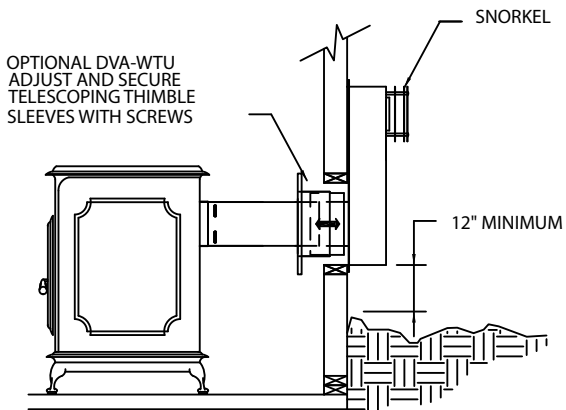

Figure 10

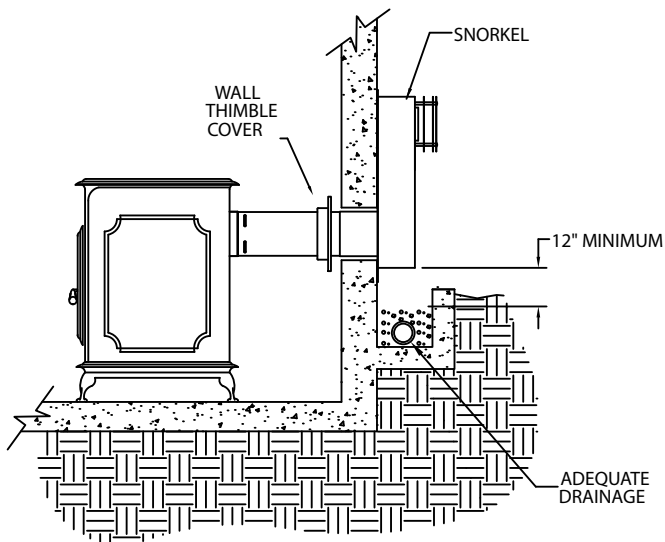

Figure 11

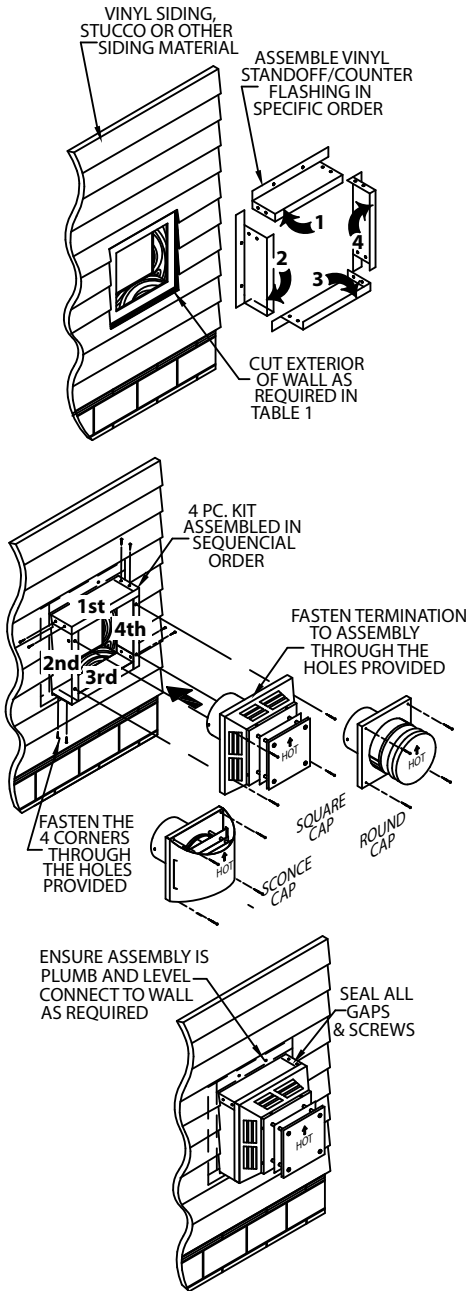

Figure 12

VINYL SIDING INSTALLATION

The Vinyl Siding Standoff prevents excessive heat from potentially warping or melting the vinyl siding material. Vinyl Siding Standoffs are not used with Snorkels. The Vinyl Siding Standoff is available in either a 1-piece version or a 4-piece version.

Installing the 1-piece Vinyl Siding Standoff:

Cut a square opening in the vinyl siding centered around the framed opening, in accordance with the dimensions provided in **Table 1, page 8**.

- Mount the Vinyl Siding Standoff to the wall using the screws provided.
- Seal around the perimeter of the Vinyl Siding Standoff using non-hardening waterproof sealant to help ensure a weather tight seal.

- Secure the Horizontal Termination Cap to the Vinyl Siding Standoff using the (4) long screws provided with the cap.

Installing the 4-piece Vinyl Siding Standoff:

The Vinyl Siding Standoff should be assembled and installed on the wall between the Horizontal Cap and the building exterior. Cut a square opening in the vinyl siding centered around the framed opening, in accordance with the dimensions provided in **Table 1, page 8**.

- The 4 pieces of the Vinyl Siding Standoff (or Counter Flashing) must be assembled in specific order to help ensure a weather tight fit.
- Loosely assemble the four parts, in order, around the opening in the vinyl siding. Place the first of 4 pieces along the upper edge of the opening in

the vinyl siding. Progressing counter-clockwise, place the left side, the bottom side, and then the right side around the opening in the siding. Refer to **Figure 12**.

- With the 4 pieces in place secure the pieces together using the pre-drilled holes and the screws provided.
- Seal around the inside corners of the Vinyl Siding Standoff to help ensure a weather tight installation.
- Attach the Horizontal Cap to the Vinyl Siding Standoff. Line up the holes in the cap with the holes in the Vinyl Siding Standoff and secure with the (4) long screws provided with the cap.
- Secure the Vinyl Siding Standoff to the wall as appropriate. Depending on the construction of your wall, different methods of securing the standoff and cap may be required. The Vinyl Siding Standoff's flanges extend 2" under the siding and can be secured to the wall by using screws through the siding and flange if needed.
- Seal around the perimeter of the Vinyl Siding Standoff using non-hardening waterproof sealant to help ensure a weather tight seal.

COUNTER FLASHING INSTALLATION

The Counter Flashing is typically installed before siding or stucco is finished and helps to ensure a weather tight penetration through the wall. The Counter Flashing allows stucco, or other materials, to be finished up to the edges of the Counter Flashing. Under no

circumstances should stucco or other material cover Termination Cap or air inlets. The Counter Flashing is available in both 1-piece and 4-piece versions.

Installing the 1-piece counter

flashing: Center the counter flashing on the wall around the framed penetration. Secure to the wall using the screws provided or other necessary connector depending on the wall material. Attach the Horizontal Cap to the Counter Flashing by lining up the holes in the cap with the holes in the Counter Flashing. Secure using the 4 long screws provided with the cap (**Fig. 12**).

Installing the 4-piece Counter

Flashing: Attach the 4 pieces together starting with the top piece and work counter-clockwise.

- Secure the 4 pieces together before mounting Counter Flashing to the wall. Mount the assembled Counter Flashing on the wall, centered around the framed wall penetration.
 - Depending on wall construction, use screws or other suitable connector through the flanged edges to secure Counter Flashing to the wall.
 - Seal around the perimeter of the Counter Flashing using non-hardening waterproof sealant to help ensure a weather tight seal.
- (4) If the optional copper version of Horizontal Termination Cap is installed, use an appropriate non-combustible material to avoid direct contact between the galvanized and copper metals to prevent possible galvanic reaction.

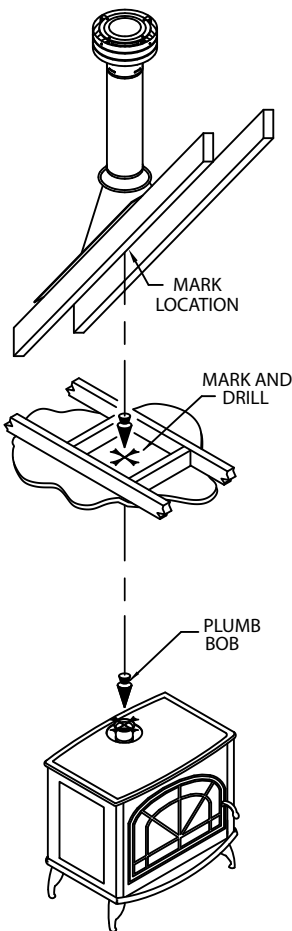

Figure 13

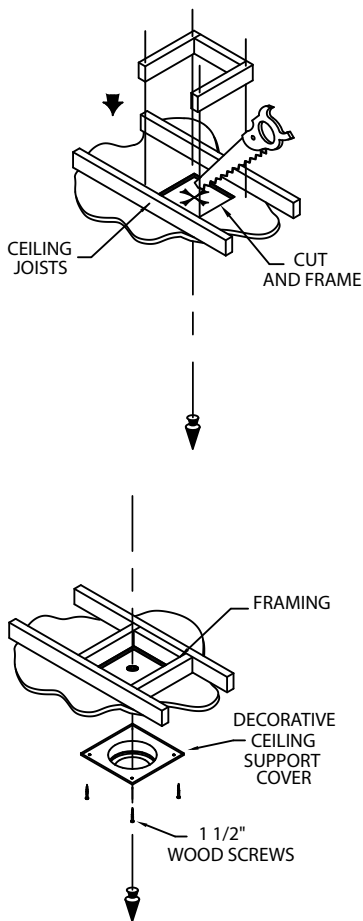

Figure 14

VERTICAL INSTALLATION

Step 1. Check the appliance manufacturer's installation instructions for required clearances (air spaces) to combustibles when passing through ceilings, walls, roofs, enclosures, attic rafters, or other nearby combustible surfaces. Do not pack air spaces with insulation. Check the appliance manufacturer's instructions for maximum vertical rise of the venting

system and any maximum horizontal offset limitations.

Step 2. Set the gas appliance in the desired location. Drop a plumb bob down from the ceiling to the position of the appliance flue exit, and mark the location where the vent will penetrate the ceiling. Drill a small hole at this point. Next, drop a plumb bob from the roof to the hole previously drilled in the ceiling, and mark the spot

where the vent will penetrate the roof (**Fig. 13**). Determine if ceiling joists, roof rafters, framing or other materials will obstruct the venting system. You may wish to relocate the appliance, or to offset, to avoid cutting load-bearing members.

Step 3. To install the Round Ceiling Support/Wall Thimble Cover in a flat ceiling, refer to **Table 1, page 8** and cut a square hole in the ceiling (unless otherwise specified by the appliance manufacturer) centered on the hole drilled in Step 2. Frame the hole as shown (**Fig. 14**).

Step 4. If the twist-lock Appliance Adaptor has not been installed on the stove by the manufacturer, install it now in accordance with the appliance instruction manual.

Step 5. Assemble the desired Pipe Sections and Elbows necessary to reach from the Appliance Adaptor up through the Round Ceiling Cover or Support Box. Ensure that all Pipe and Elbow connections are in their fully twist-locked position.

Step 6. Cut a hole in the roof centered on the small drill hole placed in the roof in Step 2. The opening should be of sufficient size to meet the minimum requirements for clearance to combustibles, as specified by the appliance manufacturer. Continue to assemble Pipe Sections and Elbows as necessary to reach up through the roofline. Galvanized Pipe and Elbows may be utilized in the attic, as well as above the roofline. The galvanized finish is desirable above the roofline, due to higher corrosion resistance.

Notes:

(1) If exact lengths or distances must be met between Elbow offsets or elsewhere, use the Pipe Extensions to adjust onto standard Pipe Sections (**Fig. 15**).

(2) If an offset is necessary in the attic to avoid obstructions, it is important to support the vent pipe in order to avoid excessive stress on the Elbows. Wall Straps or plumbers tape may be used for this purpose (**Fig. 16**).

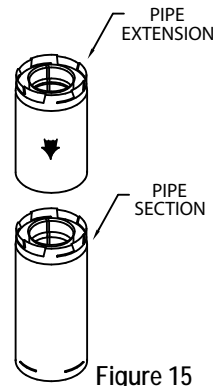

Figure 15

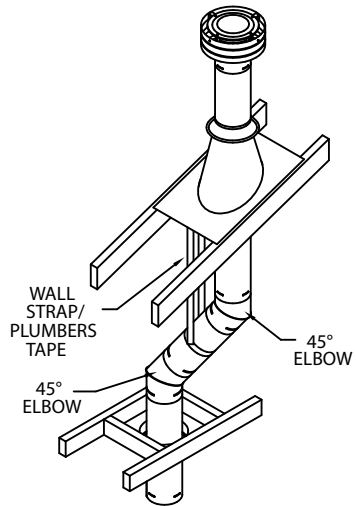

Figure 16

TABLE 2		
ROOF PITCH	MINIMUM HEIGHT	
	Feet	Meters
Flat to 7/12	1	0.3
Over 7/12 to 8/12	1.5	0.46
Over 8/12 to 9/12	2	0.61
Over 9/12 to 10/12	2.5	0.76
Over 10/12 to 11/12	3.25	0.99
Over 11/12 to 12/12	4	1.22
Over 12/12 to 14/12	5	1.52
Over 14/12 to 16/12	6	1.83
Over 16/12 to 18/12	7	2.13
Over 18/12 to 20/12	7.5	2.29
Over 10/12 to 21/12	8	2.44

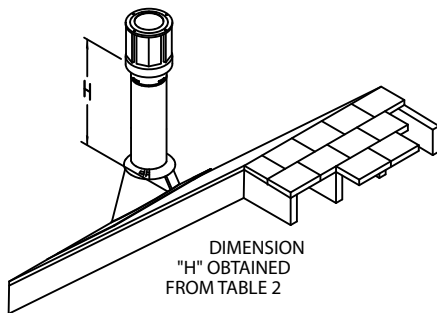

Figure 17

(3) Wherever possible, use 45° Elbows instead of 90° Elbows. The 45° Elbow offers less restriction to the flow of flue gases and intake air.

Step 7. Slip the Roof Flashing over the Pipe Section(s) protruding through the roof. Use a non-hardening sealant between the Roof Flashing and the roofing to prevent water leakage.

Secure the base of the Roof Flashing to the roof with roofing nails. Ensure the roofing material overlaps the top edge of the Roof Flashing (Fig. 18). Verify that you have at least the minimum clearance to combustibles at the roofline and in the attic.

Step 8. Continue to add Pipe Sections

until the height of the system (before adding the Cap) meets the minimum building code requirements as described in (Table 2 and Fig. 17). Note that for steep roof pitches, the vent height must be increased. In high wind conditions, nearby trees, adjoining rooflines, steep pitched roofs, and other similar factors can result in poor draft, or down drafting. In these cases, increasing the vent height or switching to the High Wind Termination Cap may help to solve the problem.

Step 9. Slip the Storm Collar over the Pipe Section, and push it down to the top of the Roof Flashing (Fig. 18). Use non-hardening sealant between the Storm Collar and the Pipe Section.

Step 10. Holding the bottom of the Termination Cap only, twist lock the cap onto the last Pipe Section protruding above the roofline.

Notes:

(1) For multi-story vertical installations, a Ceiling Firestop is required at the second floor, and any subsequent floors (Fig. 19). Refer to Table 1, page 8. Cut and frame a square opening for installation of the Ceiling Firestop.

(2) If Vent passes through any occupied areas above the first floor, including closets and storage spaces, it must be enclosed. The enclosure may be framed and sheetrocked with standard construction materials, but required clearances to combustibles must be maintained. Consult the appliance manufacturer's installation instructions for the minimum allowable clearance between the outside of

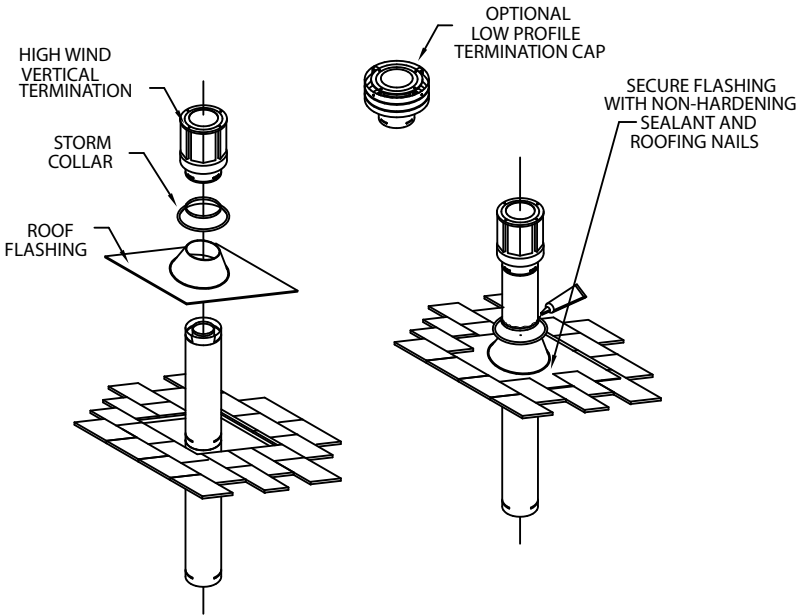

Figure 18

the vent pipe, and the combustible surfaces of the enclosure. Do not fill required air spaces with insulation. **(3)** If venting system passes through an attic space the Attic Insulation Shield or a chase enclosure must be installed to prevent contact between Pipe Sections and the insulation or other debris. For the Attic Insulation Shield, nail the base to floor of attic and adjust shield for appropriate insulation level, then attach the collar at the top of assembly (**Fig. 19**). For a chase enclosure, it may be constructed out of sheetrock or similar building materials and framed around the support box or the pipe, maintaining the clearance to combustibles as required by the appliance manufacturer. For vaulted ceilings a chase enclosure must be constructed as the Attic Insulation Shield can not be installed.

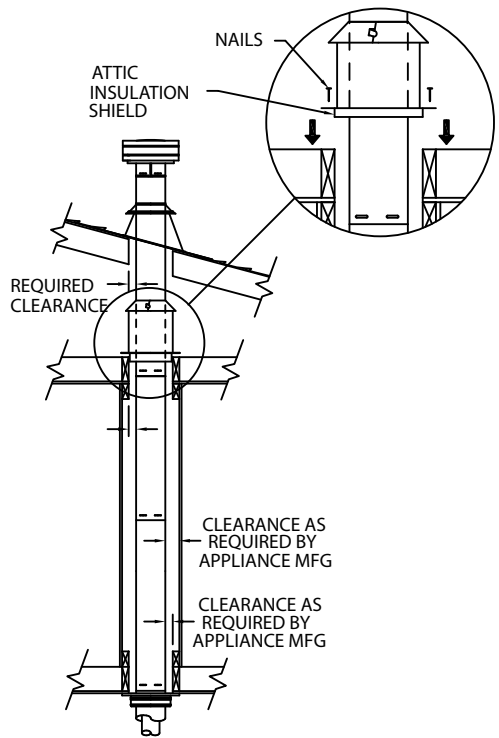

Figure 19

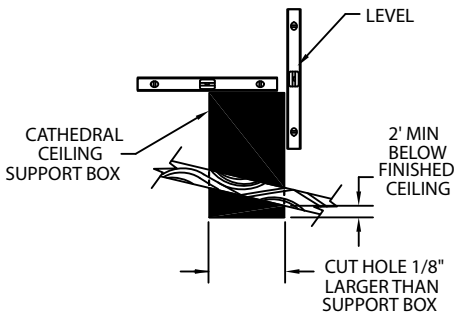

Figure 20

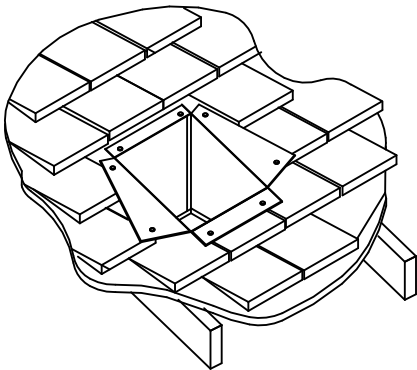

Figure 21

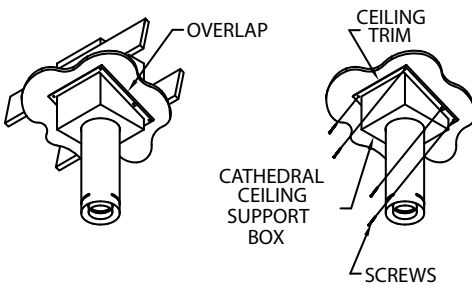

Figure 22

CATHEDRAL CEILING INSTALLATION

Step 1. Follow installation Steps 1 and 2 under Vertical Terminations.

Step 2. Using the plumb bob, mark the centerline of the venting system on the ceiling and drill a small hole through the ceiling and roof at this point. From the roof, locate the drill hole and mark the outline of the Cathedral Ceiling Support Box.

Step 3. Remove shingles or other roof covering as necessary to cut the rectangular hole for the Support Box (refer to **Table 1** for dimensions). Cut the hole 1/8-inch larger than the Support Box outline.

Step 4. Lower the Support Box through the hole in the roof until Support Box protrudes at least 2-inches below the low side of the ceiling (**Fig. 20**). Align the Support Box both vertically and horizontally with a level. Temporarily tack the Support Box in place through the inside walls and into the roof sheathing.

Step 5. Using tin snips, cut the Support Box from the top corners down to the roofline, and fold the resulting flaps over the roof sheathing. The flaps may be trimmed as needed (**Fig. 21**). Before nailing it to the roof, run a bead of non-hardening sealant around the Support Box, to make a seal between the Support Box and the roof. Clean out any combustible material from inside the Support Box.

Step 6. Follow Steps 4 and 5 (page 14) of the Vertical Installation Instructions.

Step 7. Place the Support Clamp (provided with the Support Box) inside the Support Box (at the bottom), and secure to the Pipe Section. The Clamp allows the Support Box to support the weight of the Pipe Sections. Continue to add Pipe Sections until you are above the roofline.

Step 8. Follow Steps 7 through 10 (page 15 & 16) of the Vertical Installation Instructions.

Step 9. Install the black Trim Collar around the outside of the Cathedral Ceiling Support Box. The two pieces of the Trim Collar slide over one another to allow for easy adjustment around the Support Box. Using the six (6) screws provided, secure the four corners and the overlapping sections of the Trim Collar to the underside of ceiling. You may want to pre-drill the holes for the overlapped sections for ease of installation (**Fig. 22**).

GENERAL MAINTENANCE

Conduct an inspection of the venting system annually. Recommended areas to inspect are as follows:

- 1.** Check areas of the Venting System which are exposed to the elements for corrosion. These will appear as rust spots or streaks, and in extreme cases, holes. These component should immediately be replaced.
- 2.** Remove the Vertical Termination Cap and shine a flashlight down the Vent. Remove any bird nests, or other foreign material.
- 3.** Check for evidences of excessive condensation, such as water droplets forming in the inner liner, and subsequently dripping at joints. Continuous condensate can cause corrosion of caps, pipe, and fittings. It may be caused by having excessive lateral runs, too many elbows, and exterior portions of the system being exposed to cold weather.
- 4.** Inspect joints to verify that no Pipe Sections or Fittings have been disturbed or loosened. Also check mechanical supports such as Wall Straps or plumbers tape for rigidity.

LABELS All components are labeled with the appropriate identification information, and the UL listing data, where applicable.



ROUND, SCONCE OR
SQUARE HORIZONTAL
TERMINATION CAP

SUPPLEMENTAL CANADIAN INSTRUCTIONS

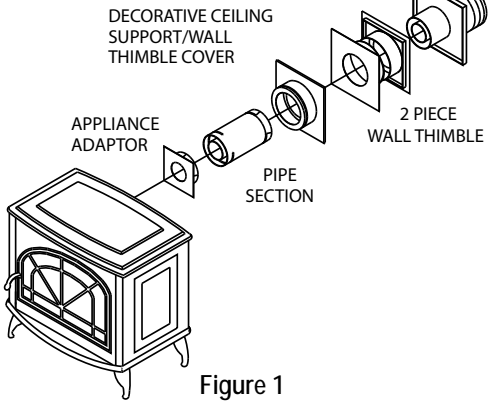

Figure 1

When installing DirectVent Pro on appliances in Canada, a 2-piece Wall Thimble is required in order to comply with IR #41 (**Fig. 1 and Fig. 2**). Cut and frame an opening in the wall in accordance with the dimensions in **Table 1, page 8**. Install galvanized exterior Wall Thimble plate on exterior of building and the other half of the Wall Thimble on the interior side of wall. Install Wall Thimble centered through a square framed opening in wall. Install a Wall Thimble Cover on the wall to cover the inside portion of the Wall Thimble. Be sure to maintain all minimum clearances specified by appliance manufacturer. When installing DirectVent Pro vertically through floors (**Fig. 3**) a Ceiling Firestop is required at every floor/ceiling level. Refer to appliance manufacturer installation instructions for complete installation procedure.

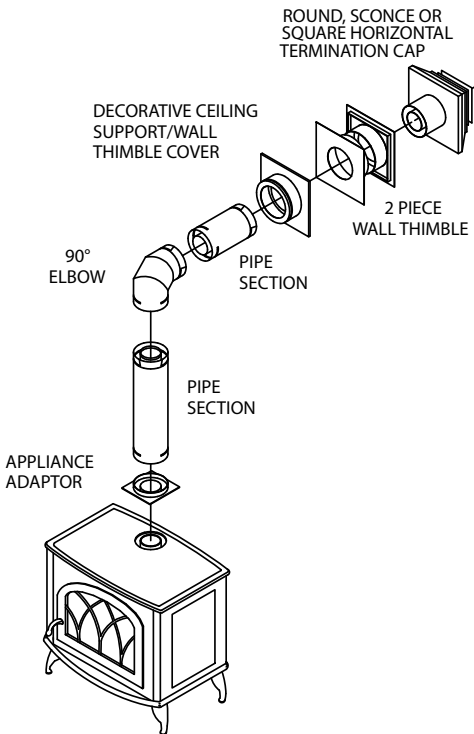

Figure 2

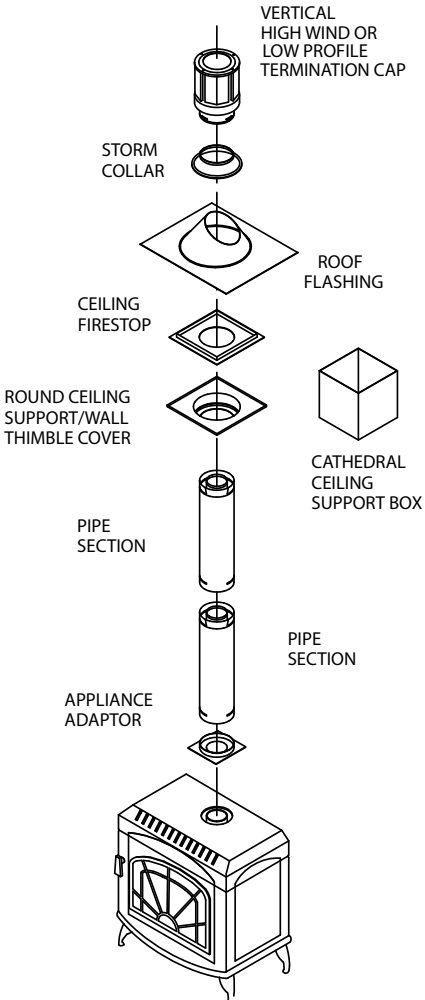

Figure 3

SIMPSON DURA-VENT LIMITED LIFETIME WARRANTY

Simpson Dura-Vent Company, Inc. ("Simpson") provides this limited lifetime warranty for all of its products to the original purchaser. Subject to the limitations set forth below, Simpson warrants that its products will be free from substantial defects in material or manufacturing, if properly installed, maintained and used. This Warranty is non-transferable and does not cover normal wear and tear, smoke damage or damage caused by chimney fires, acts of God, or any product that was: (1) purchased other than from an authorized Simpson dealer, retailer or distributor; (2) modified or altered; (3) improperly serviced, inspected or cleaned; or (4) subject to negligence or any use not in accordance with the printed materials provided with the product as determined by Simpson. This limited lifetime warranty applies only to parts manufactured by Simpson.

Simpson provides the following warranties for its products: One Hundred Percent (100%) of the purchase price or MSRP at time of purchase, whichever is lower, for 15 years from the date of purchase, and Fifty Percent (50%) thereafter, except for the following limitations: all Termination Caps and DuraBlack® are warranted at One Hundred Percent (100%) for five years, and at Ten Percent (10%) thereafter.

All warranty obligations of Simpson shall be limited to repair or replacement of the defective product pursuant to the terms and conditions applicable to each product line. These remedies shall constitute Simpson's sole obligation and sole remedy under this limited warranty. This warranty provides no cash surrender value. The terms and conditions of this limited lifetime warranty may not be modified, altered or waived by any action, inaction or representation, whether oral or in writing, except upon the express, written authority of an executive officer of Simpson.

LIMITATIONS ON INTERNET SALES:

Notwithstanding any other terms or conditions of this limited lifetime warranty, Simpson provides no warranty for the following specific products if such products are both: (a) purchased from an Internet seller; and (b) not installed by a qualified professional installer: DuraTech®, DuraPlus HTC®, PelletVent Pro®, FasnSeal®, and Simpson's relining products including DuraLiner®, DuraFlex® 304, DuraFlex® 316, DuraFlex® Pro, DuraFlex® SW, and Ventinox®. For purposes of this warranty, a trained professional installer is defined as one of the following: licensed contractors with prior chimney installation experience, CSIA Certified Chimney Sweeps, NFI Certified Specialists, or WETT Certified Professionals.

Simpson reserves the right to inspect defective product to determine if it qualifies for replacement under the terms of this limited lifetime warranty. All warranty claims must be submitted with proof of purchase. Labor and installation costs are not covered under this warranty. To obtain warranty service contact Simpson promptly at Simpson Dura-Vent Warranty Service, 877 Cotting Ct., Vacaville CA 95688, or call 800-835-4429.

WHERE LAWFUL, SIMPSON DISCLAIMS ALL OTHER WARRANTIES, INCLUDING BUT NOT LIMITED TO IMPLIED WARRANTIES OF MERCHANTABILITY AND FITNESS FOR A PARTICULAR PURPOSE. IN NO EVENT WILL SIMPSON BE LIABLE FOR INCIDENTAL, CONSEQUENTIAL, PUNITIVE OR SPECIAL DAMAGES OR DIRECT OR INDIRECT LOSS OF ANY KIND, INCLUDING BUT NOT LIMITED TO PROPERTY DAMAGE AND PERSONAL INJURY. SIMPSON'S ENTIRE LIABILITY IS LIMITED TO THE PURCHASE PRICE OF THIS PRODUCT. SOME STATES DO NOT ALLOW LIMITATIONS ON IMPLIED WARRANTIES, OR THE EXCLUSION OR LIMITATION OF INCIDENTAL OR CONSEQUENTIAL DAMAGES, SO THE ABOVE LIMITATIONS AND EXCLUSIONS MAY NOT APPLY TO YOU. THIS LIMITED WARRANTY GIVES YOU SPECIFIC LEGAL RIGHTS, AND YOU MAY ALSO HAVE OTHER RIGHTS THAT VARY FROM STATE TO STATE.

For the most up-to-date installation instructions, see www.duravent.com.

REV 2.5.09

Simpson Dura-Vent, Inc
PO Box 1510
Vacaville CA 95696-1510

Simpson Dura-Vent:
50 years of Engineered Excellence®

Manufactured in Vacaville CA
and Albany NY



Customer Service Support 800-835-4429 707-446-4740 FAX www.duravent.com

DirectVent Pro is a registered trademark of the Simpson Dura-Vent Co., Inc. All rights reserved, 2009. Made in the USA.

Simpson Dura-Vent is a division of Simpson Manufacturing Company. NYSE:SSD.