

INSTALLATION INSTRUCTIONS



Venting System For
Pellet and Corn Stoves

PELLET VENT | CORN VENT

SIMPSON

Dura-Vent

COMPLETE VENTING SOLUTIONS FOR THE HEARTH INDUSTRY

A MAJOR CAUSE OF VENT RELATED FIRES IS FAILURE TO MAINTAIN REQUIRED CLEARANCES (AIR SPACES) TO COMBUSTIBLE MATERIALS. IT IS OF THE UTMOST IMPORTANCE THAT PELLETVENT BE INSTALLED ONLY IN ACCORDANCE WITH THESE INSTRUCTIONS.

NOTE:

Read through all of these instructions before beginning your installation. Failure to install as described in this instruction will void the manufacturer's warranty, and may have an effect on your homeowner's insurance and UL listing status. Keep these instructions for future reference. This booklet also contains instructions for installing a venting system within an existing masonry chimney, and for installations passing through a cathedral ceiling.

Dear Customer, Installer, or End User:

I welcome any comments regarding matters pertaining to our Simpson Dura-Vent products. I welcome any ideas, input or complaints and I'll make sure that someone responds directly back to you.

Send your emails to:
president@duravent.com

If you are searching for tech support or product information, please phone us at 800-835-4429. Or email us at:
techsupport@duravent.com

Sincerely,
*Steve Eberhard, President and CEO
Simpson Dura-Vent Co., Inc.*

MH8381
MH14420



CONTENTS

CLEARANCES AND APPLICATIONS, IMPORTANT: CORN-BURNING APPLIANCES, VENT LISTING 4

TOOLS AND EQUIPMENT YOU MAY NEED, GENERAL INSTALLATION INSTRUCTIONS 5

INSTALLATION INTO A MASONRY FIREPLACE 9

INSTALLATION THROUGH SIDE OF MASONRY CHIMNEY 12

INSTALLATION IN A CATHEDRAL CEILING 13

CLEANING AND MAINTENANCE 15

WARRANTY 16

PELLETVENT|CORNVENT



CLEARANCES AND APPLICATIONS

Simpson Dura-Vent's PelletVent (including CornVent) is listed by Underwriters Laboratories as vent for listed oil-, pellet-, and corn-burning appliances. PelletVent and CornVent are also listed as a masonry reliner, in which case the minimum clearance is 0" from vent to masonry, and 0" clearance from the masonry to nearby combustibles. Never fill any required clearance space with insulation or any other materials. Combustible materials include (but are not limited to) lumber, plywood, sheetrock, plaster and lath, furniture, curtains, electrical wiring, and building insulation of any kind. In the United States, the minimum clearance to combustibles from PelletVent or CornVent is 1" for oil-burning, pellet-burning, and corn-burning applications.

In Canada, the minimum clearance to combustibles from PelletVent or CornVent is 1" for oil-burning applications, and 3" for pellet-burning and corn-burning applications.

A major cause of vent related fires is failure to maintain required clearances (air spaces) to combustible materials. It is of the utmost importance that double wall pellet vent be installed only in accordance with these instructions.

IMPORTANT: CORN-BURNING APPLIANCES

For corn-burning appliances, it is required that you use CornVent. CornVent has been constructed to better withstand the more corrosive exhaust of corn-burning appliances. Refer to the table below for the list of available CornVent components.

For other components not listed (components

not in contact with exhaust gases), use a regular PelletVent component (examples: Support Boxes, Tee Support Bracket, Flashing).

CornVent Parts List (available in 3" and 4" diameter)

Pipe Sections: 6", 12", 24", 36", 60" lengths

Adjustable Length Pipe

Stovetop Pipe Adapter

45 & 90 Degree Elbows

Single Tee with Clean-Out Adapter

Clean-Out Adapter

Vertical Cap

Round and Square Horizontal Caps

Wall Thimble

VENT LISTING

PelletVent and CornVent are listed (listing numbers MH8381 & MH14420) to the American standard UL 641 Type L Low Temperature Venting Systems. PelletVent and CornVent are also listed to the Canadian standards ULC S609 Standard for Low Temperature Vents Type L and ULC/ORD-C441 Standard for Pellet Vents.

INSTALLATION NOTES

For the purpose of these instructions, PelletVent will collectively include PelletVent and CornVent, unless CornVent is specifically called out. Proper planning for your PelletVent installation will result in greater safety, efficiency, and convenience, saving both time and money. Use only authorized Simpson Dura-Vent PelletVent listed parts. Do not install damaged parts. When installing a Corn-burning appliance or an appliance that can burn both pellets and corn use CornVent parts as specified above.

1. WARNING: When passing through ceilings and walls, make sure all combustible

materials and building insulation products are a minimum of 1" from the vent pipe (minimum of 3" in Canada when used on pellet- or corn-burning appliances).

2. When exiting through walls, make sure NFPA rules are followed for distance from windows and openings.
3. Do not mix and match with other products or improvised solutions.
4. Practice good workmanship. Sloppy work could jeopardize your PelletVent installation.
5. Never use a vent with an inside diameter that is smaller than the appliance flue outlet.
6. Multistory: Where PelletVent passes through the ceiling, use Simpson Dura-Vent Firestop/Support assembly.
7. PelletVent placement: When deciding the location of your stove and vent, try to minimize the alteration and reframing of structural components of the building.
8. Sections of pipe are connected to each other by pushing them firmly together and twisting. Screws are not required. If however, screws are desired, use 1/4"-long sheet metal screws. Under no circumstances, penetrate the inner liner with screws.
9. RTV Sealant may be required at all vent joints. Refer to Appliance manufacturer.
10. Never install single-wall pipe to freestanding pellet stoves. Single-wall pipe may be connected to a fireplace insert, provided it is inside the fireplace, and the fireplace has completely sealed surroundings.
11. Do not connect B-Vent pipe with aluminum liners to pellet appliances.
12. Inspections: Using pelletized fuel does not eliminate the need for inspection and cleaning. During the heating season, inspect monthly, and clean at least once a year.

TOOLS AND EQUIPMENT YOU

MAY NEED

Eye Protection High-Temperature Waterproof (RTV) Sealant
Gloves Tape Measure
Screwdriver Saber or Keyhole Saw
Hammer
PERMITS

Contact your local building department or fire officials regarding any needed permits, restrictions, and installation inspection requirements in your area.

GENERAL INSTALLATION INSTRUCTIONS

PelletVent and CornVent are listed with a minimum 1" clearance to combustibles (3" clearance in Canada when used on pellet- or corn-burning appliances), however, the Ceiling Support/Firestop Spacer, Cathedral Ceiling Support Box, Wall Thimble and Tee Support Brackets are manufactured to satisfy the clearance requirements of both US and Canada. Refer to **Table 1** for framing requirements needed for these components.

1. Follow the stove/appliance manufacturer's instructions.
 - A. Choose an appliance that is listed by a recognized testing laboratory.
 - B. Connect only one flue per appliance.
 - C. Follow the appliance manufacturer's instructions and safety manual for maximum efficiency and safety. Overfiring can damage the appliance and vent.
2. If the vent exit is on top of the stove (**Figure 1**):
 - A. Place the appliance according to the manufacturer's instructions.
 - B. Drop a plumb bob to the center of the appliance flue outlet and mark center point on the ceiling, cut a square hole in the

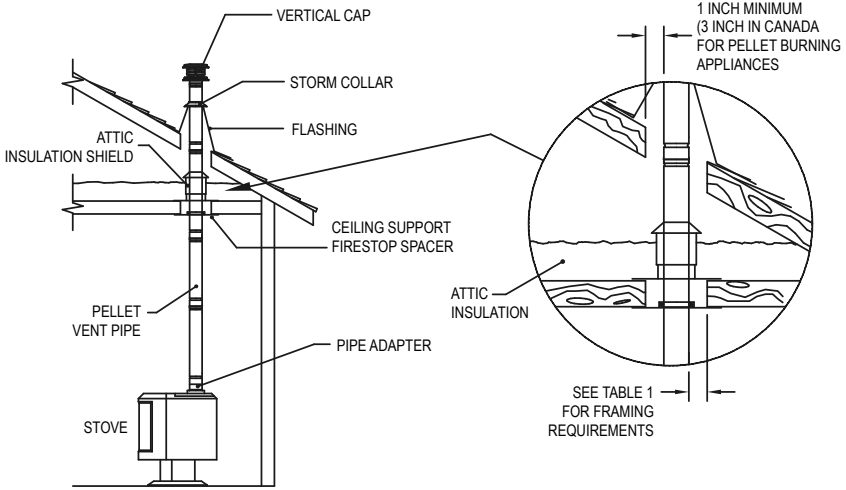

Figure 1

ceiling for the Ceiling Support Firestop Spacer. Refer to **Table 1** for the dimensions of the hole.

C. Connect Pipe Adapter to stove: Attach each section of pipe by pushing male and female ends of pipe together and twisting until pipe is in locked position.

D. When the pipe passes through the Ceiling Support Firestop Spacer at

ceiling, tighten bolt and clamp around pipe.

E. Always maintain at least 1" clearance from combustible materials (3" clearance in Canada when installed on pellet- and corn-burning appliances). Where the chimney passes through additional floors and ceilings, always install a Ceiling Support Firestop Spacer.

F. When the PelletVent enters the Attic, install an Attic Insulation Shield around the vent (**Figures 1 & 3**). This will prevent insulation and debris from collecting near the vent pipe. Use (4) wood screws to secure the base of the Attic Insulation Shield to the framed opening. Adjust the height of the Attic Insulation Shield by sliding the top cylindrical shield over the one from the base. Insure that the top of the Shield is above the level of building insulation. Secure the Shield in place with at least two (2) sheet metal screws through the side of the cylindrical shield. Attach collar around the top of the Attic Insulation shield.

G. After lining up for the hole in roof, using the same method as 2.(B), cut either a round or square hole in the roof. Always cut

Table 1

Vent Component	Framing Dimensions
3" Ceiling Support/ Firestop Spacer	9-3/4" x 9-3/4"
4" Ceiling Support/ Firestop Spacer.	10-3/4" x 10-3/4"
3" & 4" Cathedral Ceiling Support Box	10-3/4" x 10-3/4"
3" & 4" Wall Thimble	7-1/2" x 7-1/2"

the hole with the proper clearance to sides of Flashing under the roofing materials and nail to the roof along the upper edge. Do not nail across the lower edge. Seal all nail heads with non-hardening waterproof sealant. H. To finish, apply high-temperature waterproof sealant where the Storm Collar will meet the vent and Flashing; slide Storm Collar down until it sets on the Flashing, put the Cap on and twist to lock (**Figure 2**).

3. If the flue exits on back of stove and an interior installation is desired (**Figure 3**):

A. Place the appliance according to the manufacturer's instructions.

B. Connect a Pipe Adapter to the back of the stove and attach a Tee to Pipe Adapter, align, push together and twist to lock.

C. Continue to assemble pipe as described in Step 2.

4. If the flue exit is on the back of stove, and an exterior vertical installation is desired (**Figure 4**):

A. Place the appliance according to manufacturer's instructions.

B. Cut a square opening in the wall in accordance with the dimensions in **Table 1**. The black portion of the Wall Thimble is to be attached to the interior wall, and the galvanized portion (stainless steel on CornVent) is to be attached to the exterior wall. The Wall Thimble adjusts to fit walls from 3"-8" thick (**Figure 5**).

C. Connect a Pipe Adapter to back of stove; attach pipe to penetrate wall so vertical section from Tee will be 3" from the exterior of the wall. Attach a Single Tee or a Double Tee with Clean-Out Adapter, and proceed up the wall. Attach a Tee Support/Wall Strap just above the tee. A Tee Support/ Wall Strap must be placed every 4-feet along the vertical run. Assemble pipe in the same manner described in Step 2 of the general instructions. If an Adjustable Length is required in the horizontal run, and

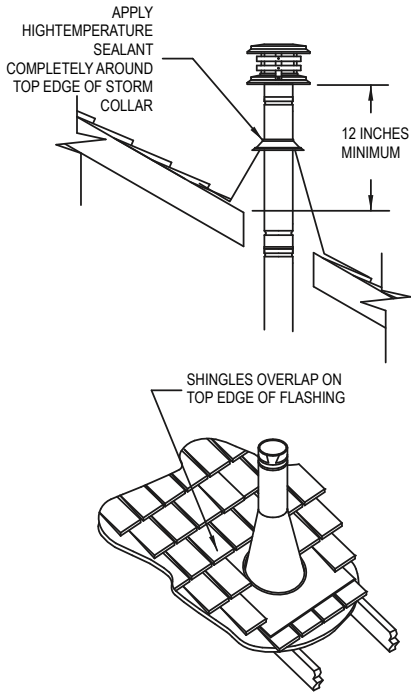

Figure 2

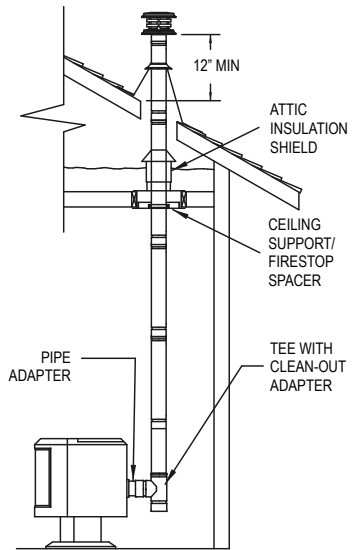

Figure 3

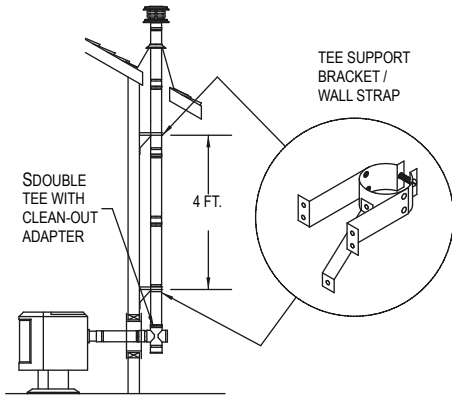

Figure 4

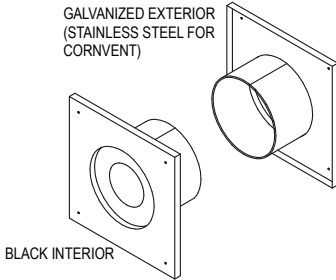

Figure 5

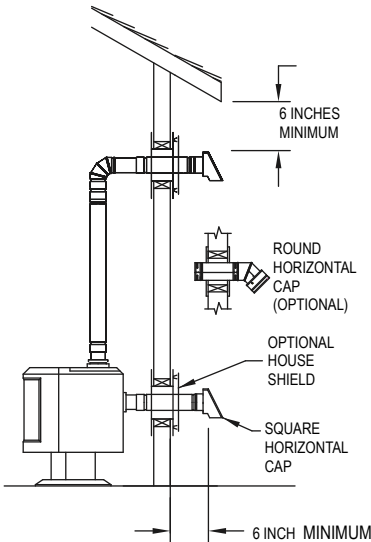

Figure 6

the Adjustable Length must enter the Wall Thimble, the diameter of the center hole in the Wall Thimble must be enlarged by $1/8"$ to accommodate the Adjustable Length.

D. Seal the exterior section of the Wall Thimble to the wall with non-hardening waterproof sealant. As an option, you may also seal the gap between the pipe and Wall Thimble with sealant.

5. If the flue exit is on back of the stove, and a horizontal through-the-wall installation is desired (**Figure 6**):

A. Place the appliance according to manufacturer's instructions.

B. Connect the Pipe Adapter to back of stove and attach sufficient pipe to penetrate Wall Thimble and extend at least 6" beyond the exterior wall. You may install the optional House Shield as shown in **Figure 6**. The House Shield is used to protect

the exterior wall from vent discharge. Attach a Square or Round Horizontal Cap. The Round Horizontal Cap can be swiveled to be directed away from nearby objects (fence, plants, etc.), but must still be pointing in a generally downward direction. Important: Horizontal Caps must be pointed in a generally downward direction to insure rain and snow do not enter the cap, and cause potential damage to the appliance. Either vent Cap should be at least 6" from the wall.

C. Follow the below listed NFPA 211 rule for distance of exit terminal from windows and openings:

NFPA 211 (2003 ed.) Section 10.4 Termination: 10.4.5 (1) The exit terminal of a mechanical draft system other than a direct vent appliance (sealed combustion system appliance) shall be located in accordance with the following:

- (a) Not less than 3 ft (.91m) above any forced air inlet located within 10 ft. (3m).
- (b) Not less than 4 ft. (1.2m) below, 4 ft. (1.2m)

horizontally from or 1 ft. (305mm) above any door, window or gravity air inlet into any building.

(c) Not less than 2 ft. (0.61m) from an adjacent building and not less than 7 ft.

(2.1m) above grade when located adjacent to public walkways.

6. If it is desired to attach to an existing 6", 7" or 8" DuraTech, DuraPlus or DuraChimney chimney, either roof supported, or ceiling supported: (**Figure 7**).

A. Remove any existing connector pipe, adapter or connector going into the ceiling support box.

B. Visually inspect with a flashlight the condition of the interior of the chimney for cleanliness and structural integrity. All evidence of soot and creosote must be removed from the existing chimney system. If you doubt your ability to accomplish this, contact a certified chimney sweep. Do not use chemical cleaners, as these can possibly damage the inside of the chimney. Do any required maintenance on the existing chimney system at this time.

C. Install a DVL/DuraBlack Chimney Adapter - product stock numbers (6") 8674, (7") 8774, or (8") 8874 - in the existing ceiling support box, as shown in **Figure 7**. Note that the DVL/DuraBlack Chimney Adapter only connects to Simpson Dura-Vent chimney systems.

D. Connect the appropriate size Chimney Adapter to the DVL/DuraBlack Chimney Adapter.

E. Connect the appliance to the Chimney Adapter using a Pipe Adapter, lengths of pipe as required, and an Adjustable Length pipe. Slide the Adjustable Length down over the top pipe section, position the installation vertically plumb, then slip the Adjustable Length up and twist lock it to the Chimney Adapter. Once all the components are firmly seated and properly aligned, carefully drill three 1/8" diameter holes through

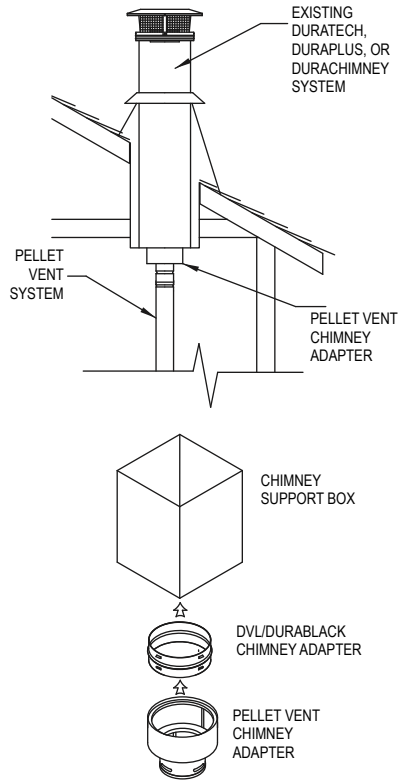

Figure 7

the outer sleeve only in the center of the slots located at the bottom of the Adjustable Length pipe. Do not penetrate the inner liner. Use (3) 3/8" length sheet metal screws to secure the Adjustable Length pipe. The completed installation will look like **Figure 7**.

INSTALLATION INTO A MASONRY FIREPLACE

1. Have the masonry chimney inspected by a certified chimney sweep or installer, to determine its structural condition.
2. Carefully read the pellet stove or insert installation instructions.
3. Measure and record the dimensions as

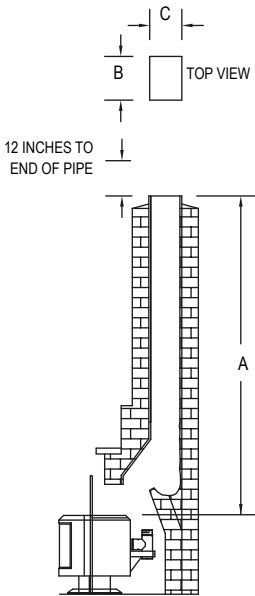

Figure 8

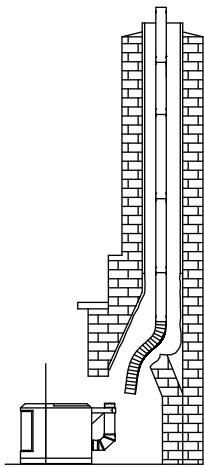

Figure 9

shown in **Figure 8**. 4. Use dimension “A” to determine total pipe requirements. Add 12 additional inches to insure the termination is an adequate distance above the roofline.

5. The gross pipe required will be “A” dimen-

sion plus 12 inches. Five feet of this will be Flex Pipe. The remainder will be rigid pipe. For each joint, subtract 1-1/2 inches to allow for the overlap. You may need extra pipe, or an adjustable length pipe section to achieve the correct height.

6. Assemble the first rigid pipe section to the Flex Pipe, insuring that the “UP” arrows shown on the pipe labels are, in fact, pointing up. Push the sections together and twist to lock. Screws are not required for a firm lock, however, should it be desired to use them, use stainless steel sheet metal screws 1/4-inch long - DO NOT penetrate the inner liner of the pipe.

7. Repeat this process for the remainder of the pipe sections, and lower the assembly down the chimney as shown in **Figure 9**. Lower it below its normal position in order to connect the Flex Pipe to the pipe on the appliance. It may be necessary to tie a line to the top section, to pull it back up later.

8. In making the connection at the appliance, configurations other than the one shown in **Figure 10** may be made. It may be necessary to contact the manufacturer of the unit to determine exactly what may or may not be done to make the correct connection. Some typical arrangements are shown in **Figures 11 and 12**. A Pipe Adapter may be needed, depending on the exit size of the stove or insert collar.

9. If a Tee is necessary to make the connection, as shown in **Figure 12**, the Tee has a removable Clean Out Adapter on its base to enable cleaning. The Tee Support Bracket to hold the Tee to the rear of the appliance is mandatory. If it is desired to mount the Tee Support to the rear of the stove, obtain approval from the manufacturer of the stove before drilling, tapping, or performing any other alterations to the appliance.

10. Connect the appliance to the coupling on the bottom of the Flex Pipe, by twisting to the

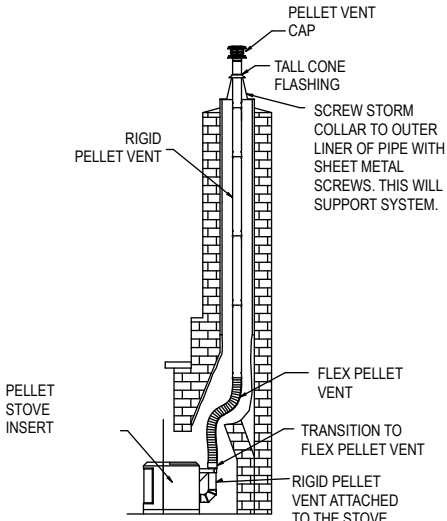

Figure 10

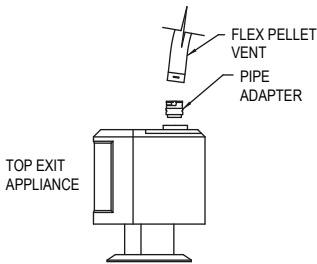

Figure 11

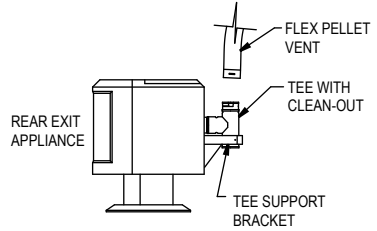

Figure 12

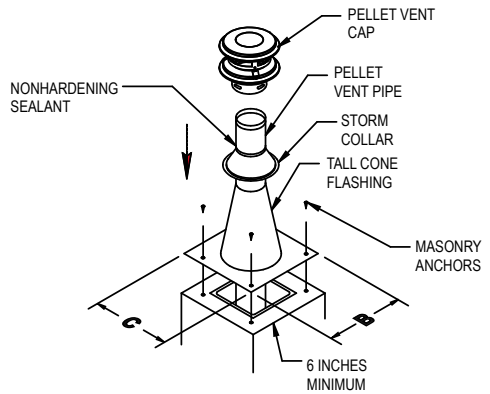

Figure 13

locked position. Push the appliance into the fireplace to its final resting place. Go to the top of the chimney and pull the vent system up to its desired height.

11. For the termination of the pellet vent, you will use a Tall Cone Flashing, and a Storm Collar. This will require 14 inches of pipe above the top of the masonry chimney. Pull the pipe up through the flashing to the desired height. Mark where the Storm Collar will go. Slip the Storm Collar down over the pipe, and affix it to the pipe with a 1/4"-long stainless steel sheet metal screw. (Figures 13 & 14). The Storm Collar will then support the entire vent system. Install the Cap. Seal the joint at the Storm Collar, and any other joints or seams which

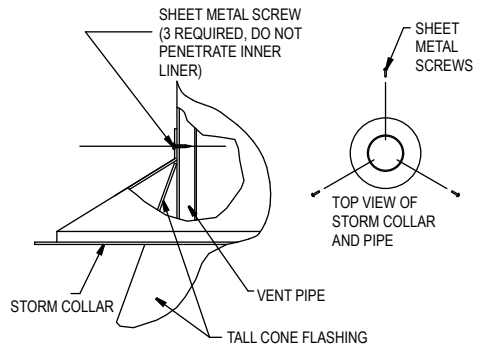

Figure 14

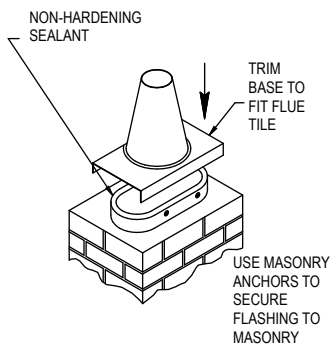

Figure 15

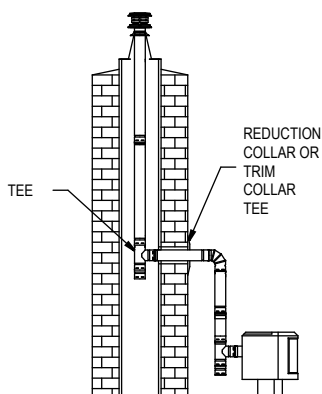

Figure 16

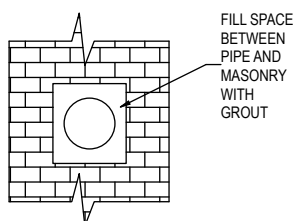

Figure 17

may appear suspect. **Figure 15** shows a Tall Cone Flashing modified to fit a chimney where the tile liner protrudes above the masonry, as another alternate termination technique. This completes the masonry installation.

INSTALLATION THROUGH SIDE OF MASONRY CHIMNEY

1. Set the appliance in its final location and mark the center of the hole where the pipe is to penetrate the masonry chimney (**Figure 16**). Insure that you comply with the manufacturer's specifications in regards to clearance and distances from combustible surfaces.

2. The pellet vent system is assembled essentially the same as previously described for installation in an existing masonry chimney with the exceptions listed:

A. No Flex Pipe is required, unless the masonry chimney has an offset. If an offset exists, then a section of Flex Pipe will be needed to accommodate the offset.

B. A Tee is installed at the bottom end of the vertical pipe (**Figure 16**).

C. A Reduction Collar or a Trim Collar is required to go around the pipe section that passes through the masonry to give it a finished look (**Figure 16**).

3. It will be necessary to break out the masonry around the location of the pipe center line mark to a diameter of at least 4 inches for 3 inch pipe, and at least 5 inches in diameter for 4 inch pipe.

4. Install the Tee on the bottom of the vertical pipe system and lower it down the chimney until the center of the branch of the Tee is level with the center of the hole in the masonry. Connect horizontal pipe section to the Tee branch.

5. Holding the pipe at the proper elevation, install the Storm Collar and Cap, as described in Step 11 for the fireplace installation. 6. Con-

nect the horizontal piece of pipe which goes through the masonry to the Tee by pushing it through the hole in the masonry, and lining it up with the branch of the Tee. Then push it into the Tee, while twisting to lock it.

7. Once the horizontal pipe section is in place, the space between the pipe and the masonry may be filled with high temperature grout, as shown in **Figure 17**, if desired.

8. Install the Reduction Collar or Trim Collar, the 90° Elbow, and the vertical pipe section going to the appliance. An Adjustable Pipe length will probably be needed, as well as a Pipe Adapter.

9. Conduct a final inspection of the entire job, and review the manufacturer's operating and installation instructions once more, before firing the appliance.

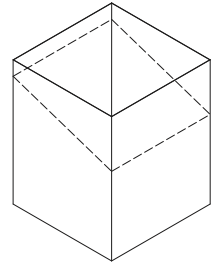

Figure 18

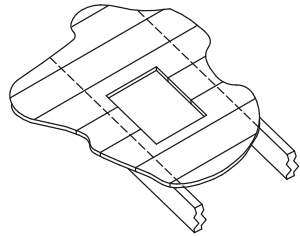

Figure 19

INSTALLATION IN A CATHEDRAL CEILING

1. Mark a line on the side of the Cathedral Ceiling Support Box to correspond to the line of the roof pitch, as shown in **Figure 18**. Allow for the Support Box to protrude below the low side of the finished ceiling a minimum of 2 inches.

2. Position the appliance at its proper location on the floor. Pay close attention to the manufacturer's installation instructions regarding the distances from combustibles, etc. The appliance must also be positioned so the Support Box will not interfere with roof rafters or other structural framing.

3. Run a plumb line from the center of the flue exit on the stove to the ceiling. Mark the point on the ceiling where the plumb line intersects. This represents the center of the support box. Drill a small hole through the ceiling at this point, so it can be located from the top of the roof.

4. From the roof, locate and mark the outline

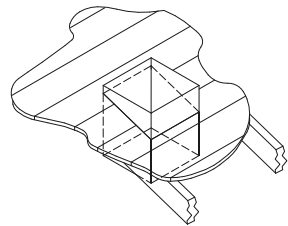

Figure 20

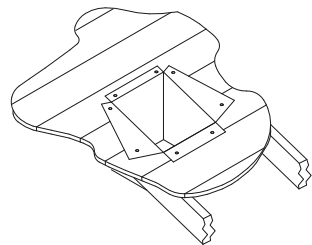

Figure 21

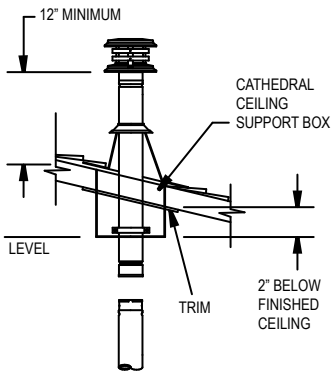

Figure 22

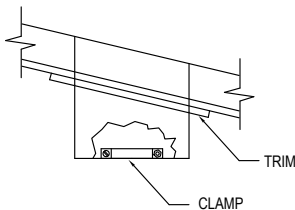

Figure 23

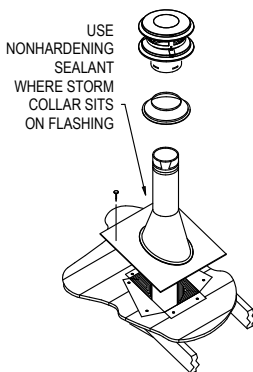

Figure 24

of the Support Box.

5. Remove shingles or other roof covering as necessary to cut the rectangular hole for the Support Box. Cut the hole 1/8-inch larger than the dimensions of the Support Box. (Figure 19). The rectangular hole should be centered on the small hole which you drilled through the ceiling to mark the location. Again, verify that you are not cutting through rafters or framing members.

6. Run the Support Box through the roof as shown in Figure 20, and place it so that the bottom of the Support Box protrudes at least 2 inches below the finished ceiling. Align the Support Box vertically and horizontally with a level. Temporarily tack the Support Box in place through the inside walls and into the roof sheathing.

7. Using tin snips, cut the Support Box from the top corners down to the roof line, and fold the resulting flap over the roof sheathing (Figure 21). Before nailing it to roof, run a bead of non-hardening sealant around the outside top edges of the Support Box so as to make a seal between the box and the roof. Clean out any combustible material or debris from inside the Support Box.

8. Place the Pipe Clamp, (which comes as a component of the Support Box) around the top of the hole in the bottom of the Support Box (Figure 23).

9. Connect the necessary amount of pipe sections to reach the stove at a point where the Cap will be at least 12-inches above the roof (Figure 22).

10. Run the assembled pieces of pellet vent pipe down through the Clamp of the Support Box and connect to the appliance with a Pipe Adapter. Using a level, make slight adjustments in the position of the appliance until the pipe is truly vertical. Tighten the bolts in the Clamp. Note that the overall length of the pellet

vent pipe as assembled, can be no longer than 42 feet.

11. Slip the Flashing over the pipe section(s) protruding through the roof. Secure the base to the roof with roofing nails as shown in **Figure 24**. Insure that the roofing material overlaps the top edge of the Flashing (**Refer to Figure 2**).

CLEANING AND MAINTENANCE

1. Have your system cleaned by a certified chimney sweep if you have doubts about your ability to clean it. Use a plastic or flexible steel brush. Do not use a stiff brush that will scratch the stainless steel liner of your system.
2. PelletVent systems must be installed so that access is provided for inspection and cleaning.
3. The pellet vent should be inspected at least once every month during the heating season.
4. Do not use chemical cleaners. They can damage the vent pipe.
5. To increase pellet vent life, coat all exterior metal parts with high temperature, rustproof paint. This is highly recommended, particularly in areas near the ocean.
6. In case of a chimney fire, close all appliance draft openings, shut off pellet appliance and call your Fire Department. Do not use the appliance or vent until it has been inspected for possible damage.
7. Simpson Dura-Vent is not responsible for flue by-products that might discolor roofs or walls.

SIMPSON DURA-VENT LIMITED LIFETIME WARRANTY

Simpson Dura-Vent ("Simpson") warrants the products identified below to the original purchaser to be free from substantial defects in material or manufacturing for the lifetime of the product, if properly installed, maintained and used. This Warranty does not cover normal wear and tear, smoke damage or damage caused by chimney fires, or any Product that was: (1) purchased other than from an authorized Simpson dealer, retailer or distributor; (2) modified or altered; (3) improperly serviced, inspected or cleaned; or (4) subject to negligence or any use not in accordance with the printed materials provided with the Product as determined by Simpson Simpson Dura-Vent. This warranty includes all components and fittings, except caps. Caps have a 5 year warranty from the date of purchase, with dated proof of purchase.. This lifetime warranty applies only to parts manufactured by Simpson Dura-Vent. This warranty may not be extended or modified by our agents or representatives.

For 15 years from the date of purchase of a **DuraTech Chimney, DuraPlus Chimney, DuraPlus HTC Chimney, PelletVent Pro, PelletVent, CornVent, DuraLiner, DuraFlex, DirectVent Pro, Type B Gas Vent, DuraConnect or DVL**, with dated proof of purchase, Purchaser's sole remedy is replacement of component fittings and chimney pipe lengths (removal and installation costs paid by Purchaser). From year 16, for the life of such Product, Purchaser's sole remedy is replacement of chimney pipe lengths at 50% of the retail list price in effect at the time of replacement (removal and installation costs and 50% of the retail list price paid by Purchaser).

For 5 years from the date of purchase of a **DuraBlack** Single-Wall Stovepipe, with dated proof of purchase, Purchaser's sole remedy is replacement of component fittings and chimney pipe lengths (removal and installation costs paid by Purchaser).

Simpson may inspect your Product to determine if, in Simpson's sole discretion, the Product qualifies for replacement under the terms of this Warranty. To obtain warranty service go to www.duravent.com or contact Simpson promptly at **800-835-4429**. The replaced Product is warranted under the terms of this Warranty.

Where lawful, Simpson disclaims all other warranties, including but not limited to implied warranties of merchantability and fitness for a particular purpose. In no event will Simpson be liable for incidental, consequential, punitive or special damages or direct or indirect loss of any kind, including but not limited to property damage and personal injury. Simpson's entire liability is limited to the purchase price of this product. Some states do not allow limitations on implied warranties, or the exclusion or limitation of incidental or consequential damages, so the above limitations and exclusions may not apply to you. This limited warranty gives you specific legal rights, and you may also have other rights that vary from state to state.

Simpson Dura-Vent, Inc
PO Box 1510
Vacaville CA 95696-1510

Simpson Dura-Vent:
50 years of Engineered Excellence®

Manufactured in Vacaville CA
and Vicksburg MS



Customer Service Support 800-835-4429 707-446-4740 FAX www.duravent.com

PelletVent Pro, DirectVent Pro, DuraTech, DuraLiner, DuraPlus HTC, DuraFlex, DVL, DuraBlack, DuraChimney II, PelletVent, CornVent, DuraPlus, DuraConnect and Dura-Vent, are registered trademarks of the Simpson Dura-Vent Co., Inc. All rights reserved, 2007. Made in the USA.

Simpson Dura-Vent is a division of Simpson Manufacturing Company. NYSE:SSD.

L502 09/2007