





# EBC 10 Fan Control

USA

CAN



-  **Product Information** ..... Chapter 1+2
-  **Mechanical Installation** ..... Chapter 3
-  **Electrical Installation** ..... Chapter 4
-  **Start Up and Configuration** ..... Chapter 5
-  **Maintenance and Troubleshooting** ..... Chapter 6

**Job Name:** \_\_\_\_\_

**Installer:** \_\_\_\_\_

**Installation Date:** \_\_\_\_\_

## READ AND SAVE THESE INSTRUCTIONS!

EXHAUSTO Inc.  
 1200 Northmeadow Pkwy.  
 Suite 180  
 Roswell, GA 30076

P: 770.587.3238  
 F: 770.587.4731  
 T: 800.255.2923  
 info@exhausto.com  
 us.exhausto.com

**EXHAUSTO**  
 VENTING DESIGN SOLUTIONS



<b>1. Product Information</b>	
1.1 Function .....	3
1.2 Shipping .....	3
1.3 Warranty .....	3
<b>2. Specifications</b>	
2.1 Dimensions & Capacities .....	4
<b>3. Mechanical Installation</b>	
3.1 Location .....	5
3.2 Mounting the Control Unit .....	5
3.3 Connection of the Proven Draft Switch .....	6
3.4 Installation of the Chimney Probe .....	6
3.5 Adjusting the Fan Speed .....	7
<b>4. Electrical Installation</b>	
4.1 General .....	8
4.2 Wiring of Heating Appliance .....	9
4.3 Wiring of Gas Fireplace .....	10
4.4 Wiring of 3-Phase Fans .....	11
4.5 Connection of an External Proven Draft Switch .....	13
<b>5. Startup and Configuration</b>	
5.1 General .....	14
5.2 Sequence of Operation .....	14
5.3 Setting the Operating Pressure .....	14
<b>6. Maintenance and Troubleshooting</b>	
.....	15

**Symbol Legend:**

The following terms are used throughout this manual to bring attention to the presence of potential hazards or to important information concerning the product.



**Danger:** Indicates an imminent hazardous situation which, if not avoided, will result in death, serious injury or substantial property damage.



**Caution:** Indicates an imminent hazardous situation which, if not avoided, may result in personal injury or property damage.



**TO REDUCE THE RISK OF FIRE, ELECTRICAL SHOCK OR INJURY TO PERSONS, OBSERVE THE FOLLOWING:**

1. Use this unit in the manner intended by the manufacturer. If you have questions, contact the manufacturer at the address or telephone number listed on the front of the manual.
2. Before servicing or cleaning the unit, switch off at service panel and lock service panel to prevent power from being switched on accidentally.
3. Installation work and electrical wiring must be done by a qualified person(s) in accordance with applicable codes and standards.
4. Follow the appliance manufacturer's guidelines and safety standards such as those published by the National Fire Protection Association (NFPA), and the American Society for Heating, Refrigeration and Air Conditioning Engineers (ASHRAE), and the local code authorities.
5. This unit must be grounded.

**How to use this manual**

This installation manual does not contain any system design documentation. System design documentation is available from any authorized EXHAUSTO representative.

Accessories, fans and variable frequency drives are not covered by this manual. Please refer to these component's individual manuals.



## 1. Product Information

### 1.1 Function

- Use** The EXHAUSTO EBC 10-P or 10-E Fan Control is for use with single heating appliances where modulation is not required. It is designed to monitor and create proper draft and pressure in a chimney system. The control may be used with EXHAUSTO fan models RS, RSV, GSV, RSIB and RSIF.
- Typical uses include controlling draft for a gas-fired water heater, boiler, furnace, fireplace, stove, BBQ or pizza oven.
- Function** The EBC 10-P integrates a fan speed control and an internal Proven Draft Switch (PDS) with a pressure probe. The EBC 10-E integrates a fan speed control only. This model must be connected to an external EXHAUSTO PDS-1 to provide the same functions as the EBC 10-P.
- The user can set the control to run the exhaust fan continuously. When used with a 3-phase exhaust fan a Variable Frequency Drive (VFD) is required. It will allow the user to manually adjust the speed of the fan while it is in use.
- The control can also be interlocked with the appliance to make the post-purge function available. The post-purge function allows the fan to operate for 3 minutes after the appliance has been shut down. This allows any excess flue gases or products of combustion to evacuate the chimney system.
- When the EBC 10 is connected to an internal or external PDS, the control provides a safety function that prevents an appliance from operating in the event of an electrical or mechanical failure. The PDS is supplied with a pressure probe that constantly senses the draft in the chimney. If insufficient draft exists, the control will gradually increase the fan speed until the draft-set point is satisfied. If this point is not satisfied after 12 seconds, the control will shut down the appliance. There is an automatic reset on the control to prevent nuisance lockouts or the need for manual reset.
- Construction** The housing is made of NEMA 1 rated polycarbonate.
- Code Compliance** System installation must conform to the requirements of the authority having jurisdiction. When required by the authority having jurisdiction, the installation must also conform to the NFPA31, NFPA54 or NFPA211.
- All electrical wiring must be in accordance with the requirements of the authority having jurisdiction or, in absence of such requirements, with the National Electric Code, NFPA 70.
- Listings** The circuit board and other components of the EXHAUSTO EBC 10 are ETL or UL listed.

### 1.2 Shipping

EBC 10-P  
EBC 10 Control Unit with internal PDS stack pressure probe and silicone tubing

EBC 10-E  
EBC 10 Control Unit without PDS  
Optional: External PDS, stack pressure probe and silicone tubing.

\* If other components are shipped, they will appear as separate items on the packing list.

### 1.3 Warranty

**Complete warranty conditions are available from EXHAUSTO, Inc.**

## 2. Specifications

### 2.1 Dimensions & Capacities

<b>EBC 10 Control</b>		
Power supply	V	1x120VAC
Amperage	A	6.3
Operating temperature	°F/°C	-4 to 122/ -20 to 50
Control signal	mA	max. 10
Control relay		Max. 120 VAC / 8A
Output	VAC	10-120
	VDC	0-10
Dimensions	A in/mm	7.17 / 182
	B in/mm	7.09 / 180
	C in/mm	4.37 / 111
Weight	lbs/kg	3.0 / 1.5
<b>Chimney Probe</b>		
Dimensions	D in/mm	4.25 / 108
	E in/mm	3.50 / 89

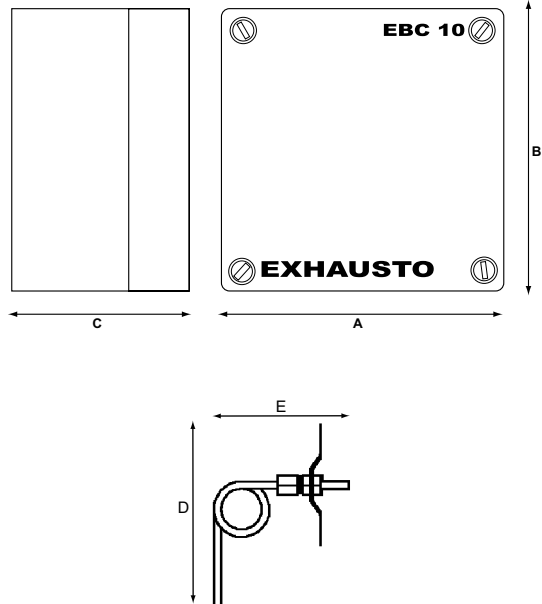

**EBC10-P**



**EBC10-E**





### 3. Mechanical Installation

#### 3.1 Location

The EBC 10 Control Unit must be installed indoors in the vertical position, preferably in the room where the appliance is located. As shown in the diagram below, the control will be wired directly to a 120/1/60 VAC power supply. The control will also be wired into the appliance and the junction box provided with the fan. For detailed wiring information, see Chapter 4.

**EBC 10-P**

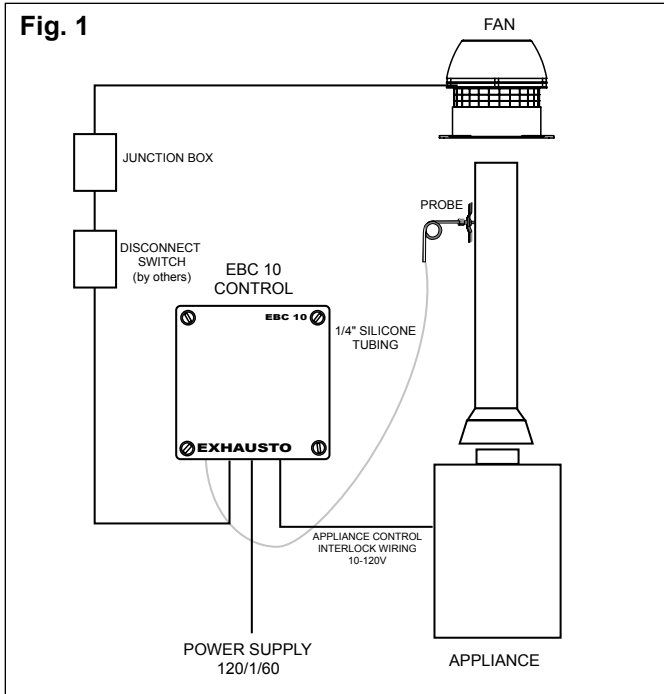

**EBC 10-E**

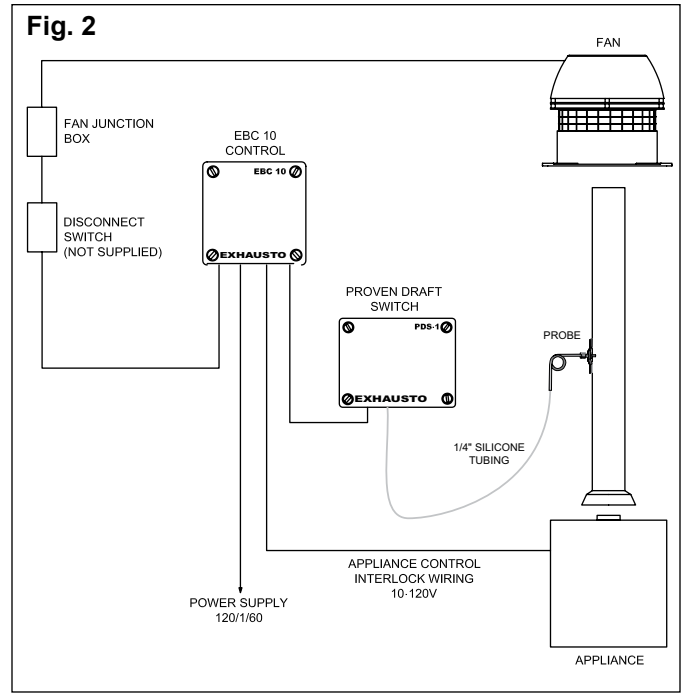

#### 3.2 Mounting the Control Unit

The EBC 10 control may be mounted directly to a wall. To mount, remove the cover and locate the (4) mounting holes. Using the hole-pattern shown below, mount the control using the appropriate sized hardware. Once it is attached, the unit may be wired in accordance with Chapter 4 and the cover may be replaced.

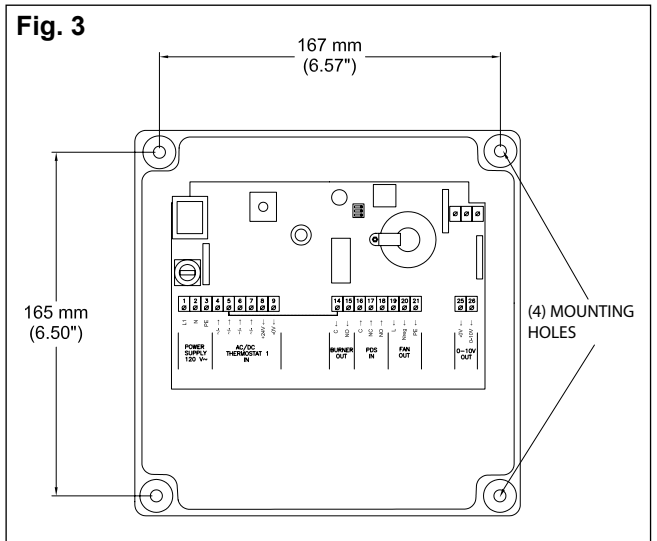

### 3.3 Connection of the Proven Draft Switch

A Proven Draft Switch (PDS) must be used with the EBC 10 control as a system safety device. The PDS monitors the pressure inside the stack and signals the control to shut down the appliance if insufficient draft exists. A stack probe senses the pressure read by the PDS and is connected via silicone tubing.

For model EBC 10-P, connect the silicone tubing through the port located at the bottom of the control enclosure as shown in Fig. 4. Connect the tubing to the NEGATIVE (-) port on the PDS. The other end should be attached to the stack probe.

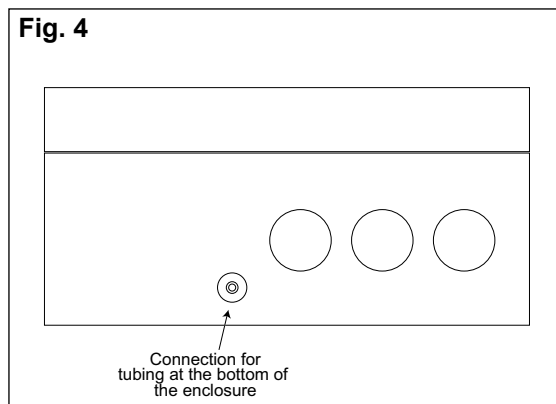

For model EBC 10-E, an external PDS-1 must be wired to terminals 16, 17 and 18 of the control. The silicone tubing will run from the PDS-1 to the pressure probe. For wiring detail, see Chapter 4.

The standard tube length is 6 feet. The distance can be extended up to 25 feet by using 1/4" rigid plastic or copper tubing as temperature allows (not supplied).

### 3.4 Installation of the Chimney Probe

The probe must be installed between the appliance and the exhaust fan.

Locate the probe at least a distance three (3) vent diameters away from any elbow or tee. For fireplace installations, the probe should be installed as close to the exhaust fan as possible. If the probe is installed on a horizontal pipe, it must be installed above the centerline of the pipe. See Fig. 5.

To produce an accurate pressure reading, the probe should be installed as close to flush as possible with the inner wall of the chimney or stack. If double walled stack is used, the probe should be flush with the inner most wall.

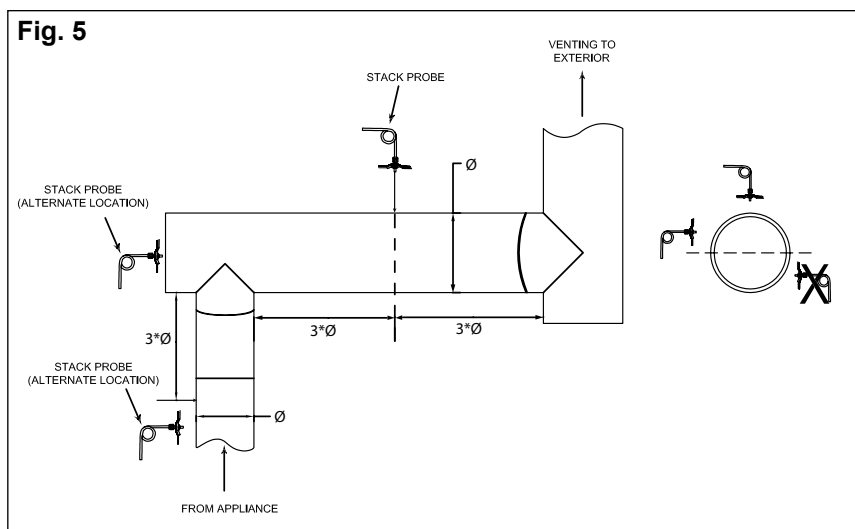

### 3.5 Adjusting the Fan Speed

A potentiometer is located on the main control board of the EBC 10. This is used to manually increase or decrease the speed of the fan. To increase the fan speed, rotate the potentiometer clockwise. Alternately, rotating the potentiometer counterclockwise will decrease the fan speed.

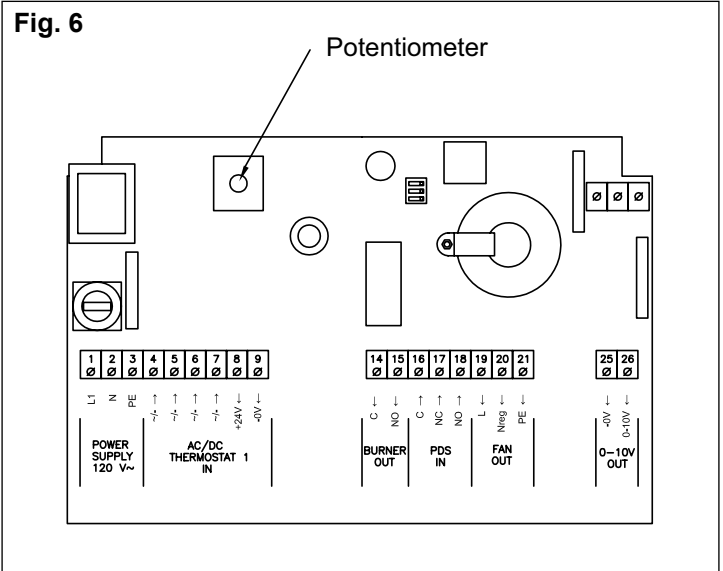

## 4. Electrical Installation

### 4.1 General



**Danger: Turn off electrical power before servicing. Contact with live electric components can cause shock or death.**



**EBC 10 is designed for 1x120VAC power supply only.**

The designations for each terminal on the control board are shown below. Note that some installations may not require the use of all terminals. Also shown in this section is a general connection diagram for an EBC 10 control system.

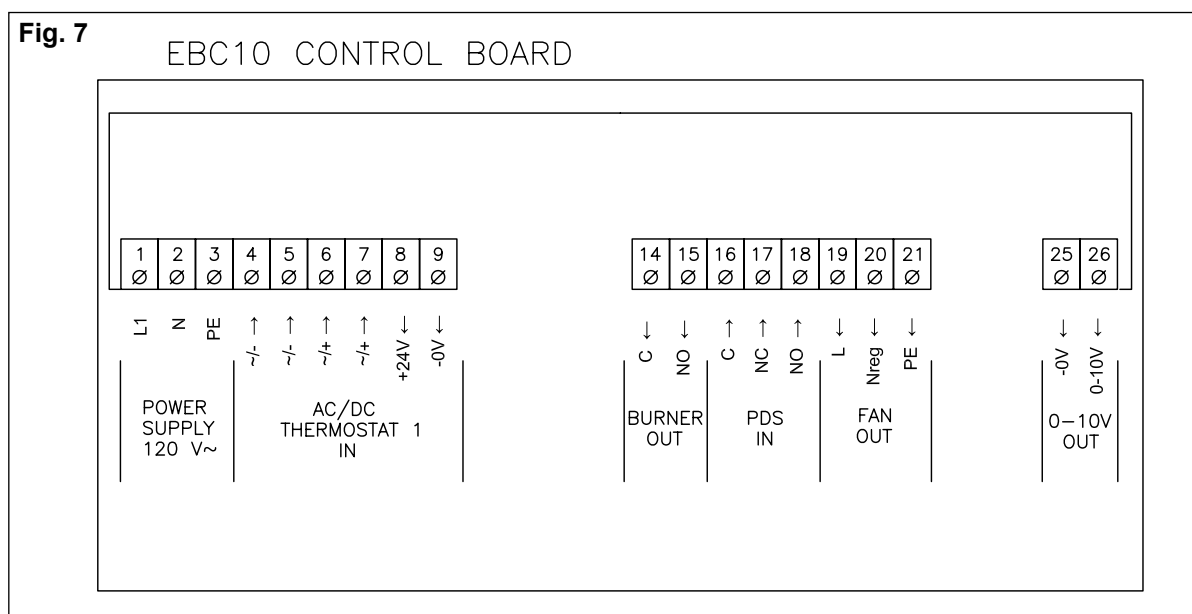

<u>Terminal</u>	<u>Use</u>	<u>Terminal</u>	<u>Use</u>
1	Power Supply - L1	16	PDS- Common
2	Power Supply - N	17	PDS- Normally Closed
3	Power Supply - Ground	18	PDS- Normally Open
4-5	Voltage Input from Appliance Thermostat Optocoupler (-) (10-120 VAC/CDC)	19	Chimney Fan- L1
6-7	Voltage Input from Appliance Thermostat Optocoupler (+) (10-120 VAC/CDC)	20	Chimney/Exhaust Fan- N (regulating)
8	24 VDC power supply to dry set of contacts (appliance thermostat)	21	Chimney/Exhaust Fan- Ground
9	0 VDC power supply to dry set of contacts (appliance thermostat)	25	Control Signal for VFD (0 VDC)
14	Burner Relay Contact- Common (MAX. 120 VAC, 8 amps)	26	Control Signal for VFD (0 to 10 VDC)
15	Burner Relay Contact- Normally Open (MAX. 120 VAC, 8 amps)		

## 4.2 Wiring of Heating Appliance

The EBC 10-P may be wired directly to the appliance control. If necessary, the control shuts the appliance down by opening the safety circuit.

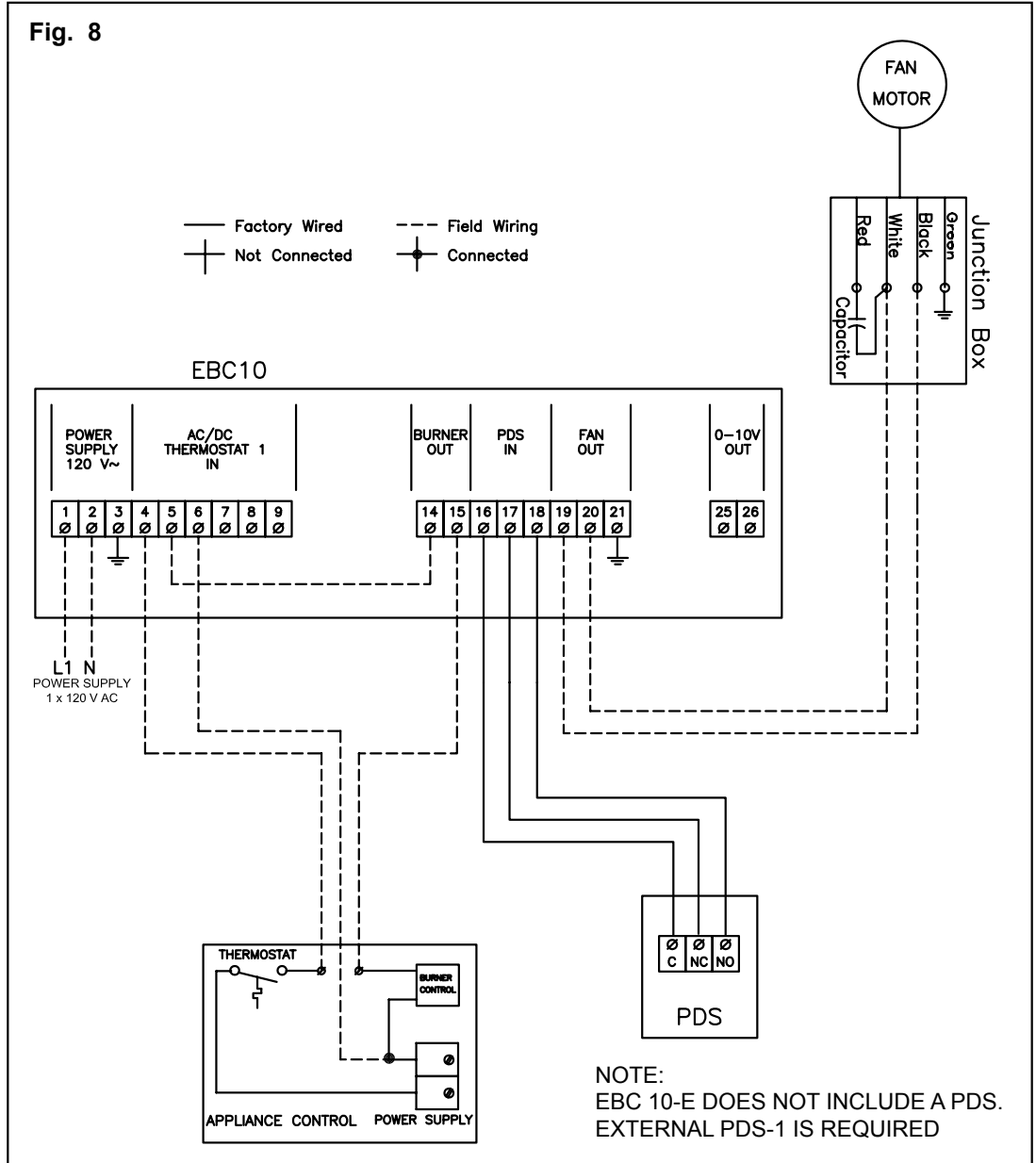

### 4.3 Wiring of Gas Fireplace

When connecting the EBC 10 to a gas fireplace, terminals 5 and 9 should be connected to a wall switch. When the switch is closed, the system is activated. Once proper draft is achieved, the control releases the gas-valve and allow fuel flow. When the switch is turned off, the control cuts off the fuel flow and the fireplace. In the event of insufficient draft or mechanical/ electrical failure, the proven draft switch and control will shut off the gas valve.

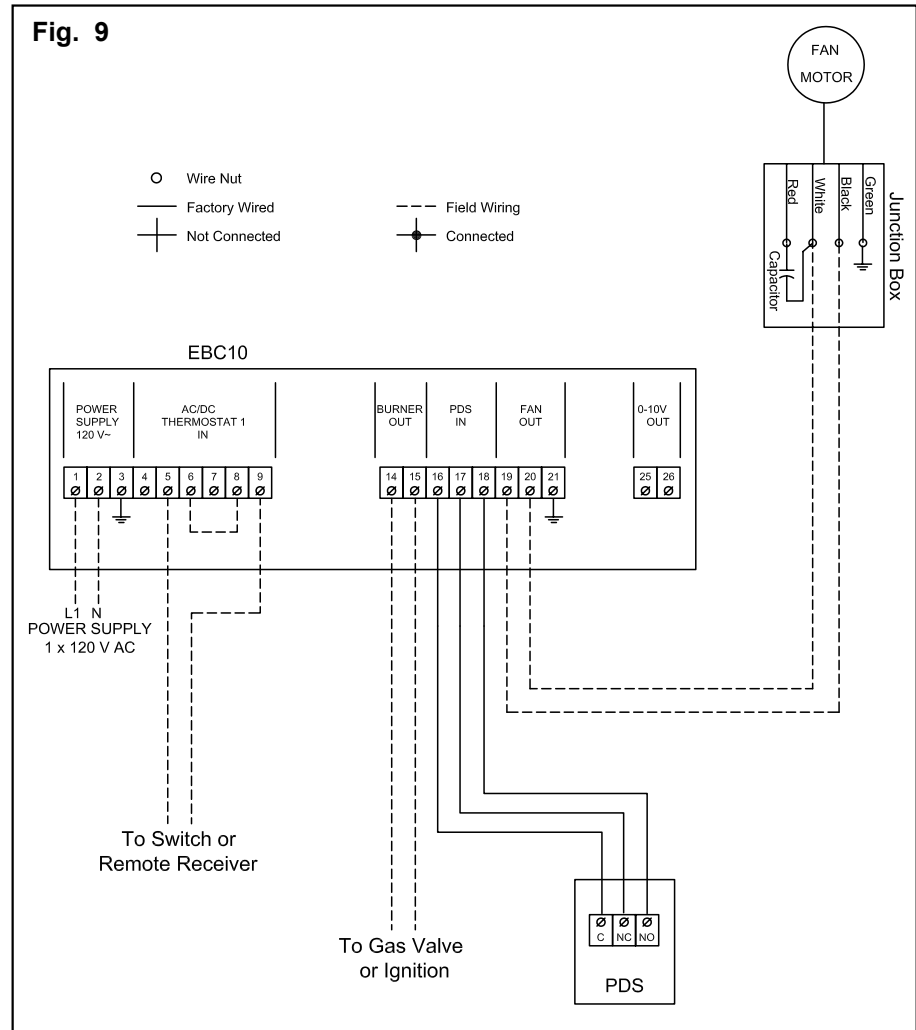

### 4.4 Wiring of 3-Phase Fans

The EBC 10 can be wired to a 3-phase fan system by incorporating a Variable Frequency Drive. Fig. 10 shows the connection diagram of this scenario. Wiring detail for this type of system is shown in Fig. 11 and Fig. 12.

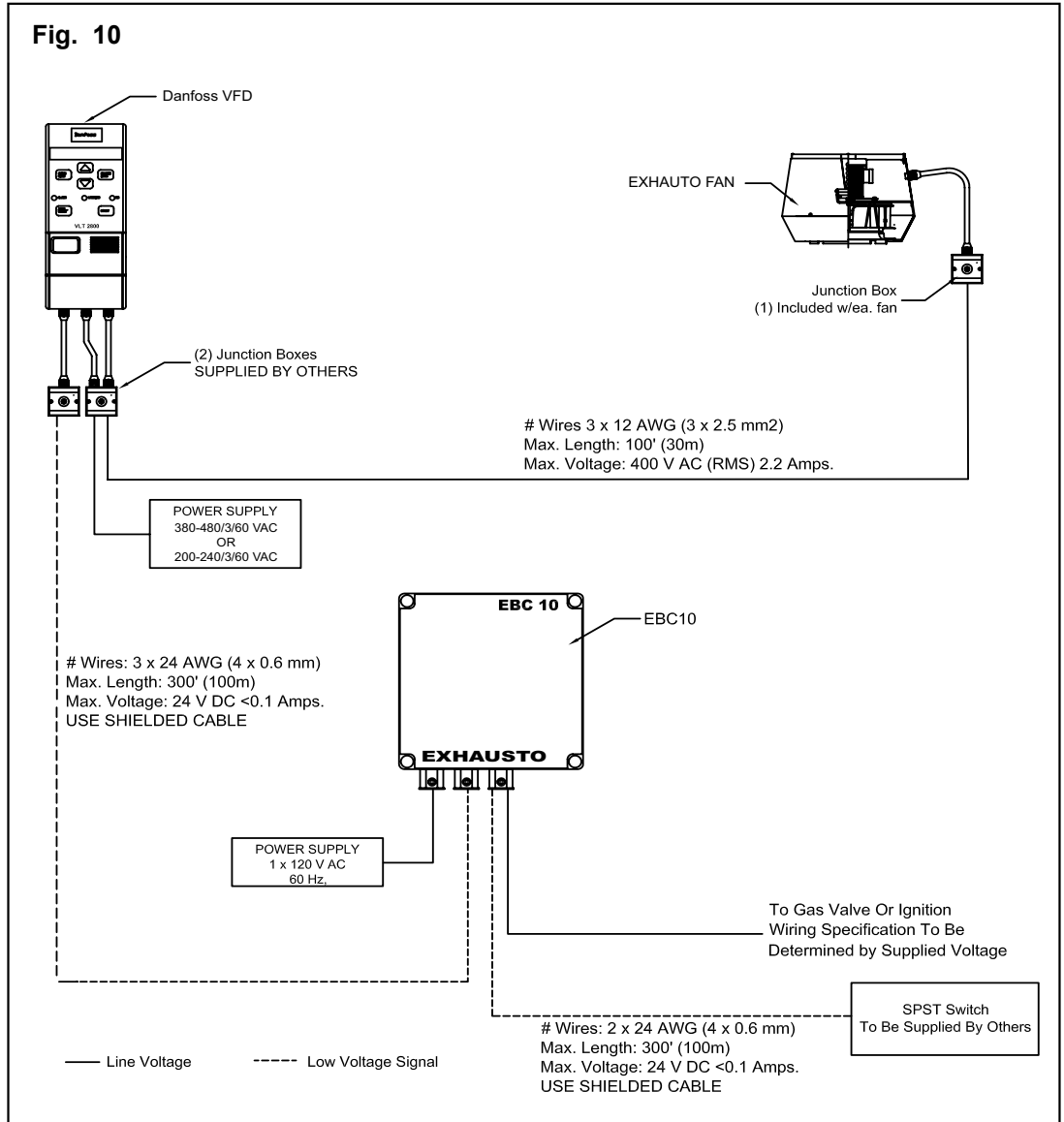

### 4.5 Wiring a Variable Frequency Drive

Connect a Variable Frequency Drive (VFD) to the EBC 10 when using a 3-phase fan. DO NOT connect a 3-phase fan directly to the control. The VFD is connected to terminals 25 and 26 of the EBC 10 control board. The wires running from the fan junction box are connected into the VFD via terminals W, V and U.

If using a VLT 2800 model VFD, wire according to Fig. 11.

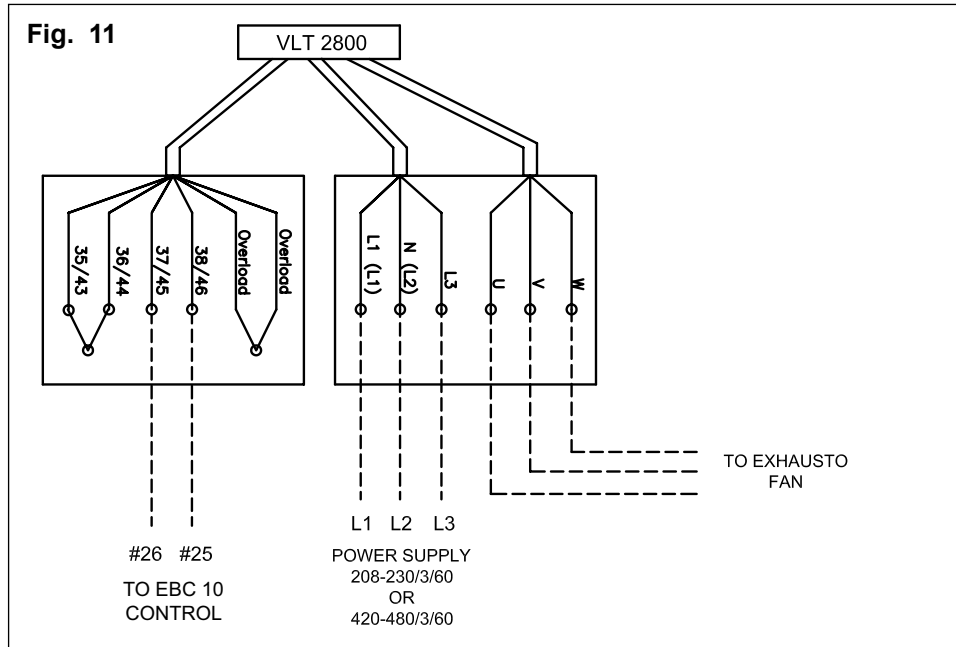

If using a VLT Micro Drive model VFD, wire according to Fig. 12.

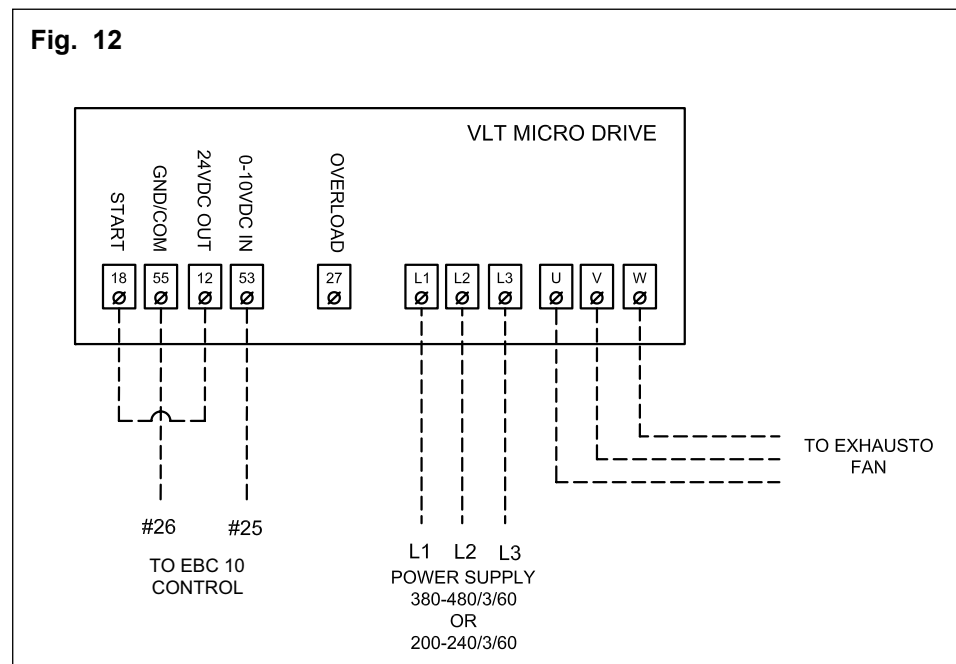

#### 4.6 Connection of an External Proven Draft Switch

For the EBC 10-E, an external PDS-1 must be installed. The wiring of this is shown in Fig. 13. A PDS-1 must be used in any of the applications mentioned previously.

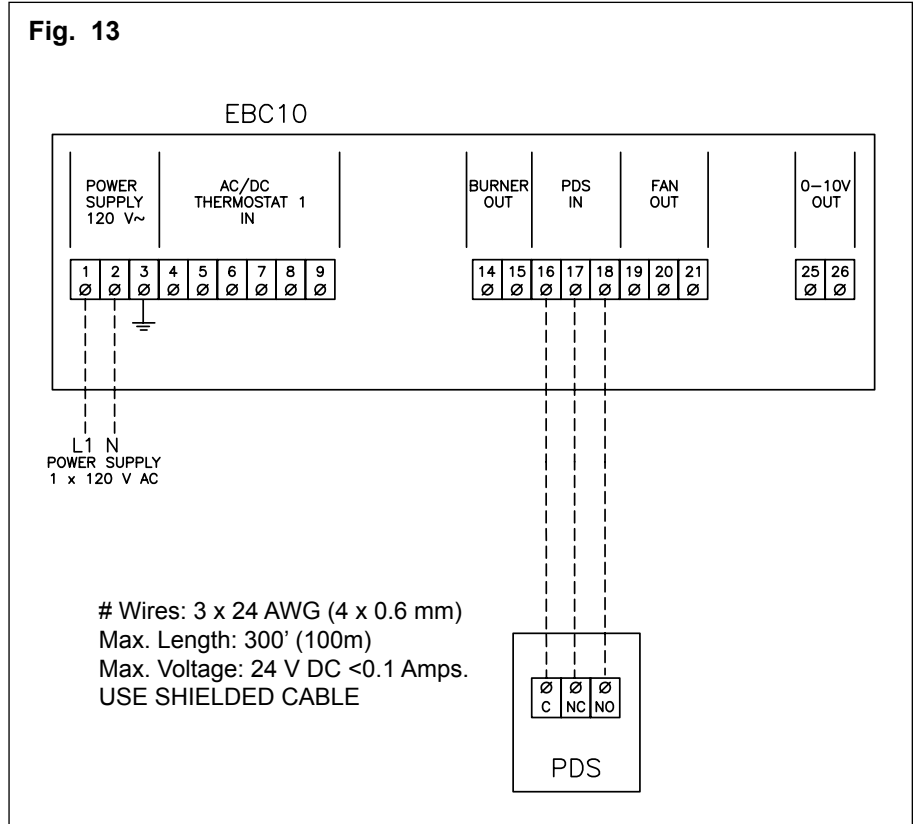



## 5. Startup and Configuration

### 5.1 General

Dip switches are located on the control board. Verify settings using the table below.

NOTE: The dip switches will always be OFF if no Proven Draft Switch is connected.

DIP SWITCH	NAME	OFF	ON
1	MANUAL RESET	Automatic reset at power failure or insufficient draft	Manual reset at power failure or insufficient draft
2	POST PURGE	No post-purge	3 minutes of post- purge
3	PDS CHECK	No monitoring to see if the PDS was in NC position prior to start	The PDS must be in NC position prior to start

### 5.2 Sequence of Operation

- Start Sequence**
1. The appliance energizes EBC 10 inputs at terminals 5 and 6 to initiate the call for heat.
  2. The EBC 10 control sets fan output to 100%.
  3. The Proven Draft Switch closes when adequate draft is achieved and EBC 10 slows fan to set speed.
  4. The EBC 10 control releases the appliance for operation by closing dry contact between terminals 14 and 15.
- Operating Sequence**
1. The control adjusts fan output to the percentage set by the control board Potentiometer.
  2. If the Proven Draft Switch opens, fan output is set to 100% and a 12 sec. timing cycle starts.
  3. If the Proven Draft Switch has not been made within 12 sec., the appliance output turns off and an alarm condition exists.
  4. If the Proven Draft Switch closes, the control automatically resumes normal operation at step 3 of start sequence.
- Shutdown Sequence**
1. The call for heat signal from the appliance is turned off.
  2. Fan output continues at pre-set speed for 3 minutes if post purge cycle is selected at dip switch.
  3. Fan output is set to zero

### 5.3 Operating Pressure

The operating pressure of the EBC 10 Control is determined by the PDS switch. The PDS used with the EBC 10-P and PDS-1 (used with EBC10-E) has a pressure setting of 0.05" W.C. +/- 0.03" W.C. As long as the pressure is within this range, the fireplace or appliance will continue to operate. Should the pressure fall outside of this range, it may be necessary to adjust the fan speed. The user may use a manometer or other device to read the pressure inside the stack.

For draft hoods or diverters and fireplaces, a standard smoke/ flame test should be performed before normal operation (specified in appliance manual).



## 6. Maintenance and Troubleshooting

Observation	Problem	Solution
<b>Heating appliance/ fireplace cycle on and off</b>	<ul style="list-style-type: none"> <li>- Fan speed control is set too low.</li> <li>- Fan speed control is bad</li> </ul>	<ul style="list-style-type: none"> <li>- Increase fan speed setting</li> <li>- Replace fan speed control.</li> </ul>
<b>Fan is 'hunting' (increasing speed and then decreasing speed constantly)</b>	<ul style="list-style-type: none"> <li>- Fan speed control is set too low.</li> <li>- Proven draft switch setting is too high</li> </ul>	<ul style="list-style-type: none"> <li>- Increase fan speed setting.</li> <li>- Lower the pressure setting on the proven draft switch</li> <li>- Move Stack Probe closer to fan.</li> </ul>
<b>Heating appliance/ fireplace will not come on</b>	<ul style="list-style-type: none"> <li>- Fan is not working</li> <li>- No power to the EBC 10</li> <li>- Proven draft switch is not properly connected to the chimney.</li> <li>- Relay or proven draft switch is bad</li> </ul>	<ul style="list-style-type: none"> <li>- Check the fan and if necessary, repair or replace. Check wiring, it may not be receiving start command.</li> <li>- Connect power to EBC 10</li> <li>- Make sure the probe is properly inserted into the stack, so the tip of the probe is flush with the inside of the chimney. If serving a fireplace the probe should be 3 to 4 below the fan.</li> <li>- Replace relay or switch</li> </ul>
<b>Heating appliance/ fireplace will not shut off</b>	<ul style="list-style-type: none"> <li>- Proven draft switch is not wired correct</li> <li>- EBC 10 is not wired correctly</li> <li>- Relay or proven draft switch is bad</li> </ul>	<ul style="list-style-type: none"> <li>- Check wiring and correct.</li> <li>- Check wiring and correct.</li> <li>- Replace relay</li> </ul>

